

RS & RT

RIDUTTORI A VITE SENZA FINE WORM GEARBOXES SCHNECKENGETRIEBE



RS & RT Riduttori a vite senza fine

Singola, precoppia e doppia
riduzione

- 7 grandezze RT
- 9 grandezze RS
- Potenze da 0.09 a 15 kW
- Rapporti da 5:1 a 10000:1
- Coppie da 8 a 3020 Nm
(con entrata 1400 min⁻¹)



RS & RT Worm speed reducers

Single, attachment and double
stage

- 7 sizes RT
- 9 sizes RS
- Powers from 0.09 to 15 kW
- Ratios from 5:1 to 10000:1
- Torques from 8 to 3020 Nm
(with 1400 rpm input)



RS & RT Schnecken- getriebe

Ein-, vor- u.
zweistufig

- 7 Größen RT
- 9 Größen RS
- Leistungen von 0.09 bis 15 kW
- Untersetzungen von 5:1 bis
10000:1
- Ausgangsdrehmoment von 8
bis 3020 Nm (

VARVEL - RS & RT

RIDUTTORI SERIE RS E RT
GEARBOXES SERIES RS AND RT
GETRIEBEBAUREIHE RS U. RT

Vite senza fine singolo

I riduttori delle serie RS e RT, specificamente concepiti per fissaggio universale, sono costruiti con carcassa e coperchi in alluminio pressofuso fino alla grandezza 85 e in ghisa dalla grandezza 110.

Le coppie indicate nelle tabelle di selezione sono coppie di uscita relative alla grandezza considerata e le potenze sono riferite a 1440 min⁻¹.

I paraolio entrata in Viton, montati su richiesta, rendono possibili senza problemi gli azionamenti con motori a 2 poli o motori c.c. a 3000 min⁻¹.

I riduttori sono spediti già riempiti con lubrificante sintetico a lunga durata (senza tappi), nelle quantità indicate a pag. 6 e valide per qualunque posizione di funzionamento.

I valori delle tabelle di selezione sono intesi per fattore di servizio FS1.0, vale a dire con funzionamento di 8-10 ore al giorno, con carico uniforme, avviamenti inferiori a 6 all'ora e temperatura ambiente fra 15 e 35 °C.

Vite senza fine con precoppia

I riduttori delle serie RA e TA, composti da un riduttore FXA indipendente a una coppia di ingranaggi montato su un riduttore standard del tipo FRS o FRT, forniscono una maggior coppia di uscita ed un più elevato rendimento degli equivalenti rapporti del tipo RT.

Vite senza fine - doppio stadio

I riduttori della serie RS/RS e RT/RT sono composti di due riduttori della serie RS o RT e forniscono un'ampia scelta di elevati rapporti a completamento della serie RA e TA per ottenere rotazioni alle più basse velocità.

AS, AD - Albero di uscita

Tutti i tipi di riduttori sono normalmente costruiti con albero uscita cavo e, a richiesta, l'albero lento sporgente in acciaio C43 può essere fornito semplice AS o doppio AD. Su richiesta è disponibile una protezione di sicurezza ASC dell'estremità non utilizzata dell'albero AS.

Braccio di reazione

I riduttori standard sono forniti normalmente su entrambi i lati con coperchi che permettono il fissaggio del braccio di reazione, quando essi debbono funzionare come riduttori pendolari. Il braccio reazione, standard o con bocca antivibrante in Vulkollan, è costruito in lamiera ad elevato spessore e zincato bianco.

Single worm gears

The worm gearboxes, RS and RT series, specifically designed for universal mounting, are manufactured with die cast housings and covers in aluminium up to the size 85 and cast iron from the size 110.

Torques listed in selection tables are output torque values for the specific size, and motor powers are always referred to 1440 rpm.

Input Viton oil seals, fitted on demand, allow free-trouble operation with 2-pole standard ac motors or 3000 rpm dc motors.

Gearboxes are delivered filled with synthetic long-life oil (without plugs), in quantities as recommended on page 6, and valid for all mounting positions.

Selection table data are intended for service factor SF1.0 i.e. 8-10 running hours per day, uniform load, less than 6 start/stops per hour, and room temperature ranging from 15 to 35 °C.

Helical worm gears

The gearboxes, RA and TA series, made up of an independent single stage helical gearbox FXA fitted to a standard FRS or FTR gearbox, allow greater output torques and higher efficiency than the FRS and FRT gearbox with equivalent ratios.

Two stage worm gears

The gearboxes, RS/RS and RT/RT series, are made up of two gearboxes RS or RT and offer a full selection of high reduction ratios to obtain the very low output speeds.

AS, AD - Output shafts

All the gearboxes are manufactured with hollow output shaft as standard version and, optionally, a single AS or double AD solid output shaft - made of steel C43 - can be supplied.

An ASC safety shield for the opposite side of a single output shaft AS, is available on demand.

Torque arms

Standard gearboxes are supplied normally with covers on each side allowing torque arm fixing when gearboxes have to operate as shaft mounted units.

The torque arm, standard or with Vulkollan vibration-damping, is made of extra thick plate and white galvanized.

Einstufig Schneckenge triebe

Die Getriebe der Serien RS u. RT, eigens für die universelle Montageanordnung entwickelt, haben bis zur Baugröße 85 Gehäuse und Deckel aus Aluminium-Druckguß und aus Guß bei Baugröße 110. Die in den Auswahl tabellen genannten Drehmomente sind jeweils die Ausgangsdrehmomente der entsprechenden Baugröße, und die Leistungen beziehen sich auf eine Nenn drehzahl von 1440 1/min. Wellendichtringe aus Viton, auf Anfrage auf der Eingangsseite montiert, ermöglichen einen problemlosen Einsatz von 2-poligen Motoren oder Gleichstrommotoren bis 3000 1/min im Dauerbetrieb. Die Getriebe werden ausgeliefert mit Langzeitschmier-mittelfüllung (ohne zusätzliche Verschluß-schrauben) und sind für alle Montagepositionen ausreichend befüllt. Die Tabellenwerte berücksichtigen einen Betriebsfaktor von FS 1.0, d.h. Betrieb 8-10 Stunden/Tag, gleichmäßige Belastung, weniger als 6 Schaltvorgängen (Start und Halt) je Stunde und Umgebungstemperaturen zwischen 15 und 35 °C.

Schneckenge triebe mit Stirnradvorstufe

Die Getriebe der Serien RA u. TA, bestehen aus einer Kombination eines separaten einstufigen Stirnradgetriebes FXA, mit einem Standard FRS oder FRT Schneckenge triebe und erlauben ein größeres Abtriebsdrehmoment bei besserem Wirkungsgrad als einstufige FRS u. FRT- Schneckenge triebe mit gleicher Übersetzung.

Doppelstufige Schneckenge triebe

Die Getriebe der Serie RS/RS u. RT/RT sind eine Kombination zweier Schneckenge triebe der RS oder RT Baureihe und bieten eine weitgehende Auswahlmöglichkeit an hohen Untersetzungen und somit sehr kleinen Abtriebsdrehzahlen.

AS, AD - Ausgangswelle

Alle Getriebe werden in Hohlwellen-Ausführung hergestellt. Als Zubehör können Einsteckwellen in der Version AS als einseitige Welle oder AD als beidseitige Welle geliefert werden. Diese Einsteckwellen sind aus C43 Stahl gefertigt. Auf Anfrage ist auch ein Wellenschutz ASC als Abdeckung eines Hohlwellenendes lieferbar.

Drehmomentstütze

Die Getriebe werden normalerweise mit Deckeln auf beiden Abtriebsseiten geliefert, die Bohrungen und Zentrierung für die Befestigung einer Drehmomentstütze besitzen, wenn das Getriebe in der Aufsteckversion eingesetzt wird. Die Drehmomentstütze, standard oder mit Dämpfungsbuchse aus Vulkollan, ist aus starkem verzinkten Blech hergestellt.

VARVEL - RS & RT

RIDUTTORI SERIE RS E RT
GEARBOXES SERIES RS AND RT
GETRIEBEBAUREIHE RS U. RT

TLI/TLE - Limitatore di coppia

Il dispositivo limitatore di coppia - TLI realizzato all'interno del riduttore e TLE installabile esternamente - permette la regolazione della coppia trasmissibile, la protezione del motoriduttore in caso d'ostacolo accidentale, il semplice sblocco del sistema e la manovra manuale in caso di mancanza di corrente. Il valore della coppia di slittamento, tarato in fabbrica, è regolabile in diminuzione dal valore di coppia massima a zero e la rotazione dell'albero di uscita riprende quando la coppia ridiscende al disotto del valore prefissato. Le quantità d'olio del limitatore TLI sono riportate a pagina 32 e 40.

SL - Limitatore di giri

Il dispositivo SL arresta - per mezzo di fine corsa interni - il funzionamento del motoriduttore dopo un tempo prefissato. La filettatura standard permette circa 40 giri dell'albero di uscita. L'escursione dei fine corsa è regolabile e il tempo di funzionamento varia da 12 a 170 secondi in relazione al rapporto utilizzato.

TLI/TLE - Torque limiters

The torque limiter and safeguard device - TLI built-in inside the gearbox and TLE fitted outside - allows easy torque adjustments, full gearbox safeguard against unexpected overload conditions, simple hand release, and manual operation in case of power supply failure.

Slipping torque, factory preset, can be adjusted from the maximum pre-set torque down to zero, and shaft rotation restarts automatically as soon as torque value is lower than the pre-set value.

Oil quantity of torque limiter TLI are listed at page 32 and 40.

SL - Travel limiters

The SL travel limiter device stops - by means of built-in limit switches - the gearbox after a given operation time.

Standard thread allows approx. 40 turns of the output shaft. Limit switch travel is adjustable and operation time varies upon the used reduction ratio from min. 12 to max. 170 seconds.

TLI/TLE- Drehmomentbegrenzer

Die TL Einrichtung ermöglicht die Einstellung der übertragbaren Drehmomente, die Absicherung vom Getriebe gegen Spitzenbelastungen, die einfache Ausschaltung der Antriebseinheit und die manuelle Bedienung im Falle eines Stromausfalles. Das Rutschmoment ist vom max. Einstellmoment bis zum Nullwert einstellbar und die Drehbewegung der Antriebswelle setzt wieder ein, sobald das Drehmoment wieder kleiner als das eingestellte Moment wird.

Ölmenge: Seite 32 u. 40

SL-Drehzahlbegrenzer

Die SL-Einrichtung stoppt, mittels eingebauten Wegschalter, das Getriebe nach einer bestimmten Zeit. Die Standardgewindespindel, ermöglicht ca. 40 Umdrehungen der Ausgangswelle. Die Wegschalter sind einstellbar und die Betriebszeit ist, abhängig von der Unterersetzung, zwischen min. 12" bis max. 170".

Direttiva ATEX

I riduttori VARVEL-ATEX, fornibili su richiesta, sono progettati e costruiti in accordo alla Direttiva 94/9/CE "Atex" e sono pertanto idonei alla installazione in atmosfere potenzialmente esplosive:

- Zone di Gruppo II,
- Categoria 2 (o 3),
- Pericolo di esplosione in presenza di Gas (Zona 1 o 2),
- Pericolo di esplosione in presenza di Polveri combustibili (Zona 21 o 22).

La serie VARVEL-ATEX viene identificata mediante la marcatura supplementare

II 2 GD ck IP66 T_{max}=135 °C

Directive ATEX

The gearboxes VARVEL-ATEX, delivered on demand, are designed and manufactured according to Directive 94/9/CE "Atex" and therefore, they are qualified for installation in potentially explosive atmospheres:

- Zones of Group II,
- Category 2 (or 3),
- Explosion hazard with gas presence (Zone 1 or 2),
- Explosion hazard with combustible dust presence (Zone 21 or 22).

The units VARVEL-ATEX are identified by the additional marking

II 2 GD ck IP66 T_{max}=135 °C

ATEX Richtlinien

Die Getriebe Varvel-Atex, ausschließlich auf Anfrage geliefert, sind entsprechend den Atex-Richtlinien 94/9/ EG "ATEX" konstruiert und hergestellt und somit zugelassen für die Installation in potentiell zündfähigen Atmosphäre:

- Gefahrenbereiche der Gruppe II
- Kategorie 2 (oder 3)
- Explosionsgefährdeter Bereich mit Gase (Gefahrenbereiche 1 oder 2)
- Explosionsgefährdeter Bereich mit zündfähigen Stäube (Gefahrenbereiche 21 oder 22).

Die Varvel-Atex Produkte sind mit folgenden zusätzlichen Stempelung versehen:

II 2 GD ck IP66 T_{max}=135 °C

VARVEL - RS & RT

RIDUTTORI SERIE RS E RT
GEARBOXES SERIES RS AND RT
GETRIEBEBAUREIHE RS U. RT

	SPECIFICHE GENERALI	GENERAL SPECIFICATIONS	ALLGEMEINE EIGENSCHAFTEN
Gamma Range Bereich	Grandezze : 9 RS + 7 RT 55 rapporti di riduzione 3020 Nm coppia uscita max	Sizes: 9 RS + 7 RT 55 reduction ratios 3020 Nm max. output torque	Baugrößen: 9 RS + 7 RT 55 Übersetzungen 3020 Nm max. Abtriebsmoment
Dimensionamento Sizing Auslegung	Secondo BS721. Vita media 15.000 ore con fattore di servizio SF1	According to BS721. 15,000 hrs average lifetime with service factor SF1	Entsprechend BS721 15T Stunden Lebensdauer für Verzahnung und Lagerung bei einem Bfaktor SF1
Carcassa, Coperchi Housing, Covers Gehäuse, Flansche	Pressofusione in alluminio AlSi12Cu2Fe fino grandezza 85 e ghisa G25 dalla grandezza 110.	Pressure die cast aluminium AlSi12Cu2Fe till size 85 and cast iron from size 110.	Aluminium-Druckguss AlSi12Cu2Fe bis Größe 85 und G25 vom Größe 110.
Parti dentate Toothed parts Verzahnung	Viti in acciaio 20MnCr5 cmt / tmp con profilo ZK rettificato. Ruote in bronzo CuSn12 su mozzo in ghisa.	Worms of steel 20MnCr5 CH and tooth profile ZK ground. Wheels of bronze CuSn12 on CI hub.	Stahl 20MnCr5 einsatzgehärtet. Zahnprofil geschliffen. Schneckenrad in Bronze CuSn12 HW Roheisen
Alberi & Linguette Shafts & Keys Wellen u. Passfedern	Acciaio C43 Alberi h6 - Fori E8 Linguette secondo DIN6885 B1	Steel C43 Shafts h6 - Bores E8 Keys according to DIN6885 B1	Stahl C43 Wellen h6 – Bohrungen E8 Passfedern nach DIN6885 B1
Cuscinetti Bearings Lagerung	Sfere o rulli secondo grandezza e specifiche tecniche	Ball- or roller-types according to sizes and technical requirements	Kugel- oder Rollenlager entsprechend den technischen Vorschriften
Paraolio Oil seals Dichtungen	Tipo NB - nitril-butadiene con secondo labbro parapolvere secondo DIN 3760	Type NB - nitril-butadiene with additional anti-dust lip according to DIN 3760	Typ NB – Nitril-Butadien mit zusätzlicher Staublippe entsprechend DIN 3760
Lubrificante Lubricant Schmierung	Olio sintetico a lunga durata Gradazione ISO VG 320	Synthetic long-life oil Grade ISO VG 320	Synthetisches Getriebeöl ISO VG 320 als Langzeit-Füllung
Verniciatura a forno Baking painting Gehäuselackierung	RS/RT ≥110: vernice a polveri epossidiche, colore std RAL 7012. RS/RT28-85: alluminio naturale.	RS/RT ≥110: epoxy powder paint, std colour RAL 7012. RS/RT28-85: real aluminium.	RS/RT ≥110: Epoxydpulverfarbe Standardfarbton RAL 7012 RS/RT28-85: Aluminium.

VARVEL - RS & RT

DESIGNAZIONE
DESIGNATION
BEZEICHNUNGEN

DESIGNAZIONE DEL RIDUTTORE

GEARBOX DESIGNATION

BEZEICHNUNG GETRIEBE

F RT [./] 40 B3 28 IEC71 B14 (OPS, OPP)

OPS= Opzioni standard pag.34-42 - *Standard options page 34-42*

Standard Optionen Seite 34-42

OPP= Opzioni piè pagina - *Options at the foot of the page -*

Optionen siehe Seitenende

B5, B14 = Forma motore - *Motor form - Motorbauform*

Grandezza motore elettrico - *Electric motor frame - Motorbaugröße*

Rapporto di riduzione - *Reduction ratio - Untersetzungsverhältnis*

Forma costruttiva - *Mounting form - Montageposition*

28, 40, 50, 60, 70, 85, 110, 130, 150 = Grandezza riduttore - *Gearbox size - Baugröße*

63/, 71/, 80/ = Grandezza precoppia - *Helical stage size - Baugröße Vorstufe*

28/, 40/, 50/ = Grandezza 1° riduttore - *1st RT/RT gearbox size - Baugröße Getriebe 1.*

RS, RA, RS/RS, RT,TA, RT/RT = Tipo riduttore - *Gearbox type - Getriebetyp*

M = Motoriduttore - *G geared motor - Getriebemotor*
 F = Flangia entrata IEC - *IEC input flange - Eingangsflansch IEC*
 S = Senza flangia IEC - *Without IEC input flange - Ohne Flansch IEC*
 ... = Senza flangia d'entrata - *Free input shaft - freie Eingangswelle*

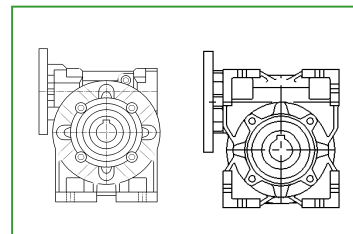

DESIGNAZIONE DEL MOTORE

MOTOR DESIGNATION

BEZEICHNUNG MOTOR

MT 0.37kW 71B 4 B14 230/400/50 IP55 F X1

Posizione morsetteria - *Terminal box position - Klemmenkastenlage*

Cl. F (std) = Classe isolamento - *Insulation class - Isolationsklasse*

IP55 (std) = Grado protezione - *Protection class - Schutzart*

Tensione/frequenza - *Voltage/frequency - Spannung/Frequenz*

Forma costruttiva - *Mounting - Bauform*

Numero poli - *Number of poles - Polzahl*

Grandezza IEC motore - *IEC motor size - Baugröße Motor*

Potenza motore - *Motor power - Leistung Motor*

MT = Motore trifase - *Three-phase motor - Dreiphasen-Motor*
 MM = Motore monofase - *Single-phase motor - Einphasen-Motor*
 MA = Motore autofrenante - *Brake motor - Bremsmotor*

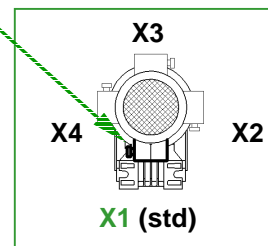

OPZIONI OPP

L'allestimento standard, ove non diversamente richiesto, è montato sul lato destro visto dall'entrata.

ACØ - Albero cavo non std Ø..
 CS - Cuscinetti uscita non std
 F - Flangia uscita F aggiuntiva
 GRI - Gioco ridotto dentatura
 GRM - Gioco ridotto montaggio
 LNS - Lubrificazione non std
 VB - Vite bisporgente

OPTIONS OPP

Standard fitting side, unless otherwise requested, is the right side of the gearbox when seen from the input side.

ACØ - Not std hollow shaft Ø..
 CS - Not std output bearings
 F - Additional output flange F
 GRI - Reduced gearing backlash
 GRM - Reduced end play
 LNS - Not std lubrication
 VB - NDE worm shaft extension

OPTIONEN OPP

Die Standardausführung, wenn nicht gesondert angefragt, wird auf die rechte Seite, vom Eingang her betrachtet, montiert.

ACØ - Sonderhohlwelle Ø..
 CS - Sonderlager Ausgang
 FL - zusätzlicher FL Ausgangsflansch
 GRI - spielarme Verzahnung
 GRM - spielarme Montage
 LNS - Sonderschmierung
 VB - Schneckenwelle beidseitig



VARVEL - RS & RT

RS-RA-RS/RS

POSIZIONI DI MONTAGGIO
STANDARD MOUNTING POSITIONS
MONTAGEPOSITION

RS , RA , RS/RS

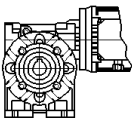
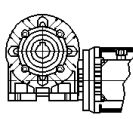
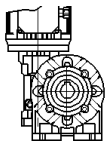
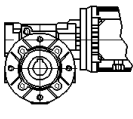
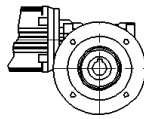
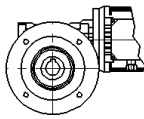
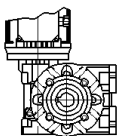
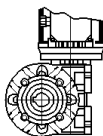
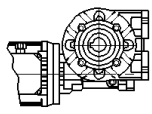
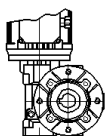
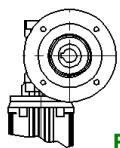
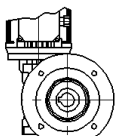
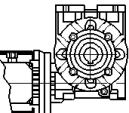
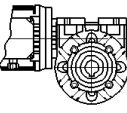
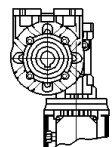
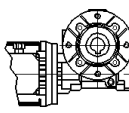
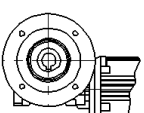
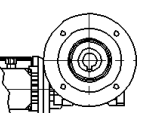
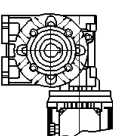
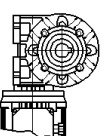
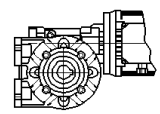
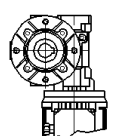
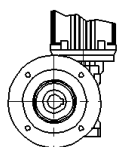
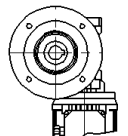
Uscita - Output - Ausgang

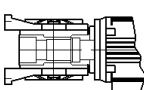
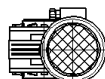
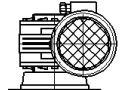
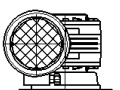
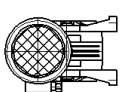
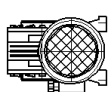
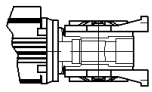
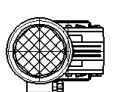
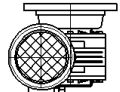
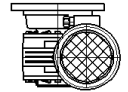
S (SA)	I (IA)	D (DA)	PC - PC	FL (FA,FB) & (PA,PB)	
 B3 (std)	 B3 (std)	 B3 (std)	 B5 (std)	 B5 (std)	 B5i
 V5	 V5	 V5	 B5	 B5a	 B5ai
 B8	 B8	 B8	 B5	 B5b	 B5bi
 V6	 V6	 V6	 B5	 B5c	 B5ci
 B6	 B6	 B6	 V1	 V1	 V1i
 B7	 B7	 B7	 V3	 V3	 V3i

RA

Entrata - Input - Eingang

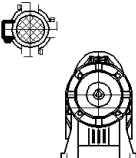
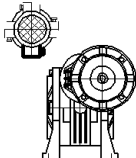
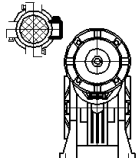
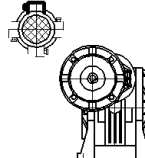
 10 (std)	 11	 12	 13		
---	---	---	---	--	--

RS/RS

VARVEL - RS & RT

POSIZIONI DI MONTAGGIO
STANDARD MOUNTING POSITIONS
MONTAGEPOSITION

RS/RS

Uscita - Output - Ausgang

	S (SA)	I (IA)	D (DA)	PC (PA, PB)	FL (FA, FB)
11					
12					
13					
14					
15					
16					
17					
18					

VARVEL - RS & RT

POSIZIONI DI MONTAGGIO
STANDARD MOUNTING POSITIONS
MONTAGEPOSITION

RT-TA-RT/RT

RT
TA
RT/RT
Uscita
Output
Ausgang

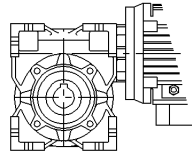

B3 (std)
V6

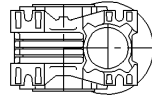

B6
F (std)

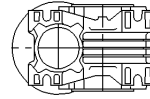

B7
Fi

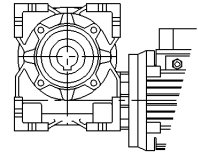

B8

V5

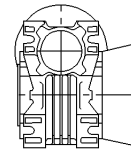
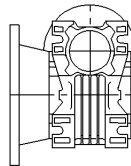
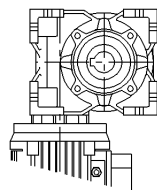
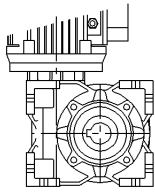

TA
Entrata
Input
Eingang



10 (std)



11



12



13

RT/RT
Entrata
Input
Eingang



20 (std)



21



22



23



24



25



26



27

VARVEL - RS & RT

FATTORI DI SERVIZIO - PESI & LUBRIFICANTI - CARICHI ENTRATA
 SERVICE FACTORS - WEIGHTS & LUBRICANTS - INPUT LOADS
 BETRIEBSFAKTOREN - GEWICHTE U. SCHMIERMITTEL - EINGANGSKRÄFTE

FATTORI DI SERVIZIO
 SERVICE FACTORS
 BETRIEBSFAKTOREN

F ₁	a	b	c	F ₂	d
3 - 4 h	0.8	1.0	1.5	6	1.0
8 - 10 h	1.0	1.2	1.8	60	1.2
10 - 24 h	1.4	1.6	2.0	120	1.4

$$FS = F_1 \times F_2$$

a = Carico uniforme Uniform load gleichmäßige Belastung
 b = Carico variabile Variable load variable Belastung
 c = Carico ad urti Shock load Stoßbelastung
 d = Avviamenti/ora Start/stops per hour Schaltungen/Stunde

- PESI &
 LUBRIFICANTI
 - WEIGHTS &
 LUBRICANTS
 - GEWICHTE &
 SCHMIERMITTEL

RS-RT	kg	l	RA-TA	kg	l _{1/2}	RS / RS RT / RT	kg	l _{1/2}
28	1.1	0.03	63 / 40	4.0	0.04/0.08	28 / 28	2.5	0.03/0.03
40	2.5	0.08	63 / 50	5.3	0.04/0.13	28 / 40	3.9	0.03/0.08
50	3.8	0.13	63 / 60	8.0	0.04/0.20	28 / 50	5.2	0.03/0.13
60	6.5	0.20	71 / 50	6.6	0.06/0.13	28 / 60	7.9	0.03/0.20
70	9.0	0.35	71 / 60	9.3	0.06/0.20	40 / 70	12.0	0.08/0.35
85	13.5	0.60	71 / 70	11.8	0.06/0.35	40 / 85	16.5	0.08/0.60
110	39.0	1.50	71 / 85	16.3	0.06/0.60	50 / 110	45.0	0.13/1.50
* 130	50.0	2.75	80 / 60	10.5	0.10/0.20	*60 / 130	57.0	0.25/2.75
* 150	80.0	4.40	80 / 70	13.0	0.10/0.35	*70 / 150	90.0	0.35/4.40

* - Solo, Only , Nur RS

80 / 85	17.5	0.10/0.60
80 / 110	43.0	0.10/1.50
100 / 110	46.0	0.20/1.50
*110/130	64.0	0.20/2.75
*110/150	94.0	0.20/4.40

CARICHI RADIALI ENTRATA R₁ [daN]

INPUT RADIAL LOADS R₁ [daN]

RADIALKRÄFTE EINGANG R₁ [daN]

$$A_1 = 0.2 \times R_1$$

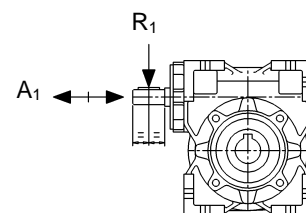

min ⁻¹	2800	1400	900	700	500	300
RS-RT 28	5	7	8	9	10	12
RS-RT 40	11	15	16	17	18	20
RS-RT 50	15	20	22	25	28	30
RS-RT 60	23	30	33	35	37	40
RS-RT 70	26	35	40	44	47	50
RS-RT 85	34	45	52	58	62	70
RS-RT 110	57	75	80	85	92	100
RS 130	70	100	105	110	115	120
RS 150	90	120	125	130	140	150

VARVEL - RS & RT

CARICHI ESTERNI
OUTPUT LOADS
AUSGANGSKRÄFTE

CARICHI RADIALI R_2 [daN] CON CUSCINETTI STANDARD
RADIAL LOADS R_2 [daN] WITH STANDARD BEARINGS
RADIALKRÄFTE R_2 [daN] MIT STANDARDLAGERUNG

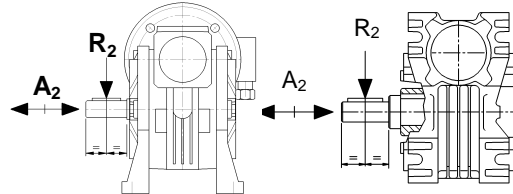

$$A_2 = 0.2 \times R_2$$

min ⁻¹	280	200	140	93	70	50	35	29	25	20	18	14	Brg No.
RS-RT28	---	45	50	55	60	62	70	75	80	90	95	100	16005
RS-RT40	100	100	110	120	135	150	160	170	180	190	200	230	16006
RS-RT50	145	125	145	170	190	200	230	240	260	280	290	320	16008
RS-RT60	225	240	250	290	330	360	390	430	460	500	530	560	①
RS-RT70	260	270	290	360	390	420	450	520	550	590	630	670	②
RS-RT85	330	330	370	440	470	540	550	630	660	710	750	830	③
RS-RT110	---	390	415	520	540	590	570	750	780	800	880	980	④
RS130	---	500	585	615	650	660	780	880	950	970	1050	1150	6015
RS150	---	650	770	830	880	900	1100	1200	1250	1300	1400	1500	6216

- ① RS: 6008 / RT: 6208 ③ RS: 6010 / RT: 6210
② RS: 6009 / RT: 6209 ④ RS: 6012 / RT: 6212

CARICHI RADIALI R_2 [daN] CON CUSCINETTI RINFORZATI
RADIAL LOADS R_2 [daN] WITH HEAVY DUTY BEARINGS
RADIALKRÄFTE R_2 [daN] MIT VERSTÄRKTER LAGERUNG

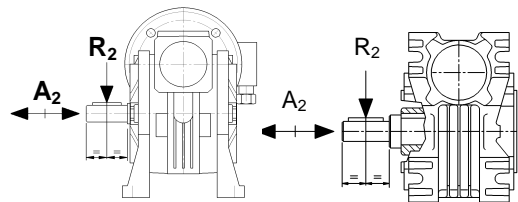

$$A_2 = 0.2 \times R_2$$

min ⁻¹	280	200	140	93	70	50	35	29	25	20	18	14	Brg No.
RS-RT28	---	65	75	82	90	93	105	112	120	130	130	130	6005
RS-RT40	140	150	155	165	190	210	225	240	250	260	260	260	32006
RS-RT50	200	175	200	240	260	300	340	360	390	420	420	420	32008
RS-RT60	290	300	320	370	420	480	510	570	610	660	660	660	30208
RS-RT70	335	330	370	450	516	560	610	690	730	790	790	790	⑤
RS-RT85	410	420	460	550	630	720	730	840	870	940	940	940	⑥
RS-RT110	---	500	540	670	750	800	930	1050	1110	1110	1110	1110	⑦
RS130	---	700	790	860	970	990	1170	1290	1420	1450	1450	1450	32015
RS150	---	900	1080	1160	1320	1350	1650	1800	1870	1950	1950	1950	30216

- ⑤ RS:32009 / RT: 30209 ⑥ RS: 32010 / RT: 30210 ⑦ RS:32012 / RT: 30212

VARVEL - RS & RT

GRANDEZZE MOTORI "RS - RT"
 MOTOR FRAMES "RS - RT"
 BAUGRÖßEN MOTOR "RS - RT"

FRS FRT	min ⁻¹ IEC	i = 5	7	10	15	20	28	40	49	56	70	80	100
		280	200	140	93	70	50	35	29	25	20	18	14
28	56	---	⊙	⊙	⊙	⊙	⊙	⊙	⊙	⊙	⊙	⊙	⊙
	63	---	⊙	⊙	⊙	⊙	⊙	⊙	⊙	⊙	⊙	⊙	⊙
40	56	⊙	⊙	⊙	⊙	⊙	⊙	⊙	⊙	⊙	⊙	⊙	⊙
	63	⊙	⊙	⊙	⊙	⊙	⊙	⊙	⊙	⊙	⊙	⊙	⊙
	71	⊙	⊙	⊙	⊙	⊙	⊙	⊙	⊙	⊙	⊙	⊙	⊙
50	63	⊙	⊙	⊙	⊙	⊙	⊙	⊙	⊙	⊙	⊙	⊙	⊙
	71	⊙	⊙	⊙	⊙	⊙	⊙	⊙	⊙	⊙	⊙	⊙	⊙
	80	⊙	⊙	⊙	⊙	⊙	⊙	⊙	⊙	⊙	⊙	⊙	⊙
60	71	⊙	⊙	⊙	⊙	⊙	⊙	⊙	⊙	⊙	⊙	⊙	⊙
	80	⊙	⊙	⊙	⊙	⊙	⊙	⊙	⊙	⊙	⊙	⊙	⊙
	90	⊙	⊙	⊙	⊙	⊙	⊙	⊙	⊙	⊙	⊙	⊙	⊙
70	71	⊙	⊙	⊙	⊙	⊙	⊙	⊙	⊙	⊙	⊙	⊙	⊙
	80	⊙	⊙	⊙	⊙	⊙	⊙	⊙	⊙	⊙	⊙	⊙	⊙
	90	⊙	⊙	⊙	⊙	⊙	⊙	⊙	⊙	⊙	⊙	⊙	⊙
	100	⊙	⊙	⊙	⊙	⊙	⊙	⊙	⊙	⊙	⊙	⊙	⊙
85	80	⊙	⊙	⊙	⊙	⊙	⊙	⊙	⊙	⊙	⊙	⊙	⊙
	90	⊙	⊙	⊙	⊙	⊙	⊙	⊙	⊙	⊙	⊙	⊙	⊙
	100/112	⊙	⊙	⊙	⊙	⊙	⊙	⊙	⊙	⊙	⊙	⊙	⊙
110	90	---	⊙	⊙	⊙	⊙	⊙	⊙	⊙	⊙	⊙	⊙	⊙
	100/112	---	⊙	⊙	⊙	⊙	⊙	⊙	⊙	⊙	⊙	⊙	⊙
	132	---	○	○	○	○	○	○	○	○	○	○	○
130	90	---	○	○	○	○	○	○	○	○	○	○	○
	100/112	---	⊙	⊙	⊙	⊙	⊙	⊙	⊙	⊙	⊙	⊙	⊙
	132	---	⊙	⊙	⊙	⊙	⊙	⊙	⊙	⊙	⊙	⊙	⊙
150	90	---	○	○	○	○	○	○	○	○	○	○	○
	100/112	---	⊙	⊙	⊙	⊙	⊙	⊙	⊙	⊙	⊙	⊙	⊙
	132	---	⊙	⊙	⊙	⊙	⊙	⊙	⊙	⊙	⊙	○	○
	160	---	⊙	⊙	⊙	⊙	⊙	⊙	⊙	⊙	○	○	○

- ⊙ - B5 & B14 (Giunto G - Coupling G - Kupplung G)
- ⊙ - B5 (Giunto G - Coupling G - Kupplung G)
- - B5 & B14 (Foro IEC - IEC bore - Bohrung IEC)
- - B5 (Foro IEC - IEC bore - Bohrung IEC)

VARVEL - RS & RT

GRANDEZZE MOTORI "RA - TA"
MOTOR FRAMES "RA - TA"
BAUGRÖßEN MOTOR "RA - TA"

FR A	IEC	7	10	15	20	28	40	49	56	70	80	100
	*	**	**	**	**	**	**	**	**	**	**	**
6	56	①	①	①	①	①	①	①	①	①	①	①
6	B5&B14	①	①	①	①	①	①	①	①	①	①	①
6		---	---	---	---	①	①	①	①	①	①	①
6	63	①	①	①	①	①	①	①	①	①	①	①
6	B5&B14	①	①	①	①	①	①	①	①	①	①	①
6		---	---	---	---	①	①	①	①	①	①	①
7	71	②	②	②	②	②	②	②	⑦	⑦	⑦	⑦
7	B5&B14	②	②	②	②	②	②	②	②	②	②	②
7		②	②	②	②	②	②	②	②	②	②	②
7		---	---	---	---	---	②	②	②	②	②	②
8	80	③	③	③	③	③	⑧	⑧	⑧	⑧	⑧	⑧
8	B5&B14	③	③	③	③	③	③	③	⑧	⑧	⑧	⑧
8		③	③	③	③	③	③	③	③	③	③	③
80		④	④	④	④	③	③	③	③	③	③	③
8	90	③	③	③	③	③	⑧	⑧	⑧	⑧	⑧	⑧
8	B5&B14	③	③	③	③	③	③	③	⑧	⑧	⑧	⑧
8		③	③	③	③	③	③	③	③	③	③	③
80		④	④	④	④	③	③	③	③	③	③	③
100		④	④	④	④	③	③	③	③	③	③	③
100	90 B5&B14	⑤	⑤	⑤	⑤	⑤	⑤	⑤	⑤	⑤	⑤	⑤
100	100 B5&B14	⑤	⑤	⑤	⑤	⑤	⑤	⑤	⑤	⑤	⑤	⑤
100	90 B5&B14	⑥	⑥	⑥	⑤	⑤	⑤	⑤	⑤	⑤	⑤	⑤
100	100 B5&B14	⑥	⑥	⑥	⑤	⑤	⑤	⑤	⑤	⑤	⑤	⑤

* - Entrata precoppia

** - Uscita precoppia & Entrata FRS

① - ø105 x 14

② - ø120 x 19

③ - ø140 x 24

④ - ø140 x 28

⑤ - ø200 x 28

⑥ - ø200 x 28 (Foro vite ø38 mm & Boccia ø38/ø28)

⑦ - ø120 x 14

⑧ - ø140 x 19

* - Helical stage input

** - Helical stage output & FRS input

① - ø105 x 14

② - ø120 x 19

③ - ø140 x 24

④ - ø140 x 28

⑤ - ø200 x 28

⑥ - ø200 x 28 (Wormshaft bore ø38 mm & Adapter bush ø38/ø28)

⑦ - ø120 x 14

⑧ - ø140 x 19

* - Eingang der Vorstufe

** - Eingang der FRS

① - ø105 x 14

② - ø120 x 19

③ - ø140 x 24

④ - ø140 x 28

⑤ - ø200 x 28

⑥ - ø200 x 28 (Schneckebohrung ø38 mm & Buchse ø38/ø28)

⑦ - ø120 x 14

⑧ - ø140 x 19

RS-RT (2800 min⁻¹)

VARVEL - RS & RT

TABELLA SELEZIONE
SELECTION TABLE
AUSWAHLTABELLE

RS RT	i =	5	7	10	15	20	28	40	49	56	70	80	100
	min ⁻¹	560	400	280	187	140	100	70	57	50	40	35	28
RS - RT 28	kW	---	0,63	0,49	0,35	0,25	0,23	0,16	0,13	0,12	0,09	0,08	0,04
	Nm	---	13	14	14	13	15	14	13	12	11	10	7
	eff.	---	0,86	0,83	0,79	0,77	0,69	0,64	0,61	0,54	0,49	0,49	0,46
RS - RT 40	kW	2,1	1,5	1,2	0,82	0,56	0,49	0,36	0,30	0,26	0,21	0,19	0,15
	Nm	32	31	34	34	30	34	32	31	30	29	28	26
	eff.	0,89	0,87	0,85	0,81	0,78	0,72	0,66	0,62	0,6	0,57	0,54	0,51
RS - RT 50	kW	3,8	3,0	2,0	1,5	0,95	0,92	0,63	0,51	0,43	0,33	0,31	0,23
	Nm	58	62	59	61	52	66	59	56	53	46	49	40
	eff.	0,90	0,88	0,86	0,82	0,8	0,75	0,69	0,66	0,64	0,58	0,58	0,52
RS - RT 60	kW	5,8	4,4	3,5	2,6	1,9	1,6	1,1	0,72	0,73	0,60	0,52	0,34
	Nm	90	93	104	110	108	116	105	85	92	92	85	68
	eff.	0,90	0,88	0,87	0,84	0,82	0,76	0,73	0,71	0,66	0,64	0,6	0,58
RS - RT 70	kW	8,1	5,7	4,3	3,2	2,4	2,2	1,5	1,2	1,0	0,80	0,69	0,54
	Nm	126	122	130	139	136	161	155	142	130	120	115	107
	eff.	0,91	0,89	0,88	0,85	0,83	0,78	0,74	0,7	0,68	0,63	0,61	0,58
RS - RT 85	kW	13,0	9,6	7,5	5,3	4,3	3,1	2,4	2,0	1,7	1,3	1,1	0,93
	Nm	202	205	225	234	237	235	250	242	229	210	200	190
	eff.	0,91	0,89	0,88	0,86	0,8	0,8	0,76	0,72	0,71	0,67	0,64	0,6
RS - RT 110	kW	---	17,5	14,8	10,7	8,6	7,0	5,0	4,5	3,6	3,1	3,0	2,1
	Nm	---	375	445	470	490	530	520	545	490	525	540	450
	Eff.	---	0,9	0,88	0,86	0,84	0,79	0,76	0,73	0,71	0,7	0,67	0,62
RS 130	kW	---	26,3	21,6	15,8	12,2	9,4	7,7	6,0	5,3	3,9	3,3	2,4
	Nm	---	565	655	705	715	715	815	740	780	670	620	560
	eff.	---	0,9	0,89	0,87	0,86	0,8	0,78	0,74	0,77	0,72	0,68	0,68
RS 150	kW	---	37,0	29,6	22,8	17,1	13,6	10,7	8,5	6,6	5,5	4,9	3,6
	Nm	---	795	900	1015	1005	1065	1170	1090	970	950	915	845
	eff.	---	0,9	0,89	0,87	0,86	0,82	0,8	0,77	0,77	0,72	0,68	0,68

VARVEL - RS & RT

RS-RT (1400 min⁻¹)

TABELLA SELEZIONE
SELECTION TABLE
AUSWAHLTABELLE

RS RT	i =	5	7	10	15	20	28	40	49	56	70	80	100
	min ⁻¹	280	200	140	93	70	50	35	29	25	20	18	14
RS - RT 28	kW	---	0,45	0,33	0,23	0,16	0,16	0,10	0,09	0,08	0,06	0,05	0,03
	Nm	---	18	18	18	16	20	17	17	15	12	12	8
	eff.	---	0,84	0,81	0,77	0,74	0,66	0,62	0,57	0,51	0,45	0,45	0,43
RS - RT 40	kW	1,5	1,1	0,81	0,55	0,38	0,37	0,25	0,21	0,18	0,14	0,12	0,09
	Nm	45	45	46	44	39	48	42	41	38	36	32	29
	eff.	0,87	0,85	0,83	0,78	0,75	0,68	0,61	0,58	0,56	0,52	0,50	0,46
RS - RT 50	kW	2,7	1,8	1,3	0,93	0,63	0,63	0,41	0,37	0,31	0,25	0,20	0,13
	Nm	81	75	75	74	65	85	72	76	71	63	58	43
	eff.	0,88	0,86	0,84	0,78	0,76	0,71	0,64	0,62	0,60	0,53	0,52	0,47
RS - RT 60	kW	4,1	2,8	2,3	1,6	1,2	1,0	0,75	0,62	0,54	0,46	0,37	0,25
	Nm	125	113	133	130	122	139	135	128	123	122	106	83
	eff.	0,89	0,86	0,84	0,81	0,77	0,71	0,66	0,62	0,60	0,55	0,53	0,49
RS - RT 70	kW	5,7	4,0	3,1	2,2	1,8	1,5	1,2	0,84	0,74	0,58	0,50	0,37
	Nm	176	166	180	188	194	216	238	189	180	163	154	130
	eff.	0,89	0,88	0,86	0,83	0,81	0,75	0,71	0,67	0,64	0,59	0,56	0,52
RS - RT 85	kW	9,1	6,2	4,6	3,4	2,9	2,2	1,6	1,4	1,2	0,96	0,86	0,55
	Nm	279	259	268	289	322	319	325	316	305	290	280	210
	eff.	0,90	0,88	0,86	0,83	0,82	0,76	0,72	0,67	0,68	0,63	0,60	0,56
RS - RT 110	kW	---	12,5	9,0	6,5	5,7	4,4	3,5	2,7	2,2	2,0	1,5	1,1
	Nm	---	525	532	560	647	642	691	631	595	635	525	469
	eff.	---	0,88	0,87	0,84	0,83	0,76	0,73	0,71	0,70	0,67	0,66	0,61
RS 130	kW	---	19,0	15,0	11,0	8,5	7,5	5,5	3,9	3,7	2,7	2,4	1,8
	Nm	---	807	890	960	975	1100	1140	950	1005	865	810	750
	eff.	---	0,89	0,87	0,85	0,84	0,77	0,76	0,72	0,71	0,67	0,63	0,61
RS 150	kW	---	24,9	21,0	16,0	12,5	9,5	8,0	5,9	5,1	3,8	3,3	2,6
	Nm	---	1060	1260	1410	1430	1435	1680	1440	1420	1230	1170	1120
	eff.	---	0,89	0,88	0,86	0,84	0,79	0,77	0,73	0,73	0,68	0,65	0,63

RS-RT (900 min⁻¹)

VARVEL - RS & RT

TABELLA SELEZIONE
SELECTION TABLE
AUSWAHLTABELLE

RS RT	i =	5	7	10	15	20	28	40	49	56	70	80	100
	min ⁻¹	180	128	90	60	45	32	23	19	16	13	11	9
RS - RT 28	kW	---	0,36	0,24	0,18	0,13	0,12	0,08	0,07	0,06	0,04	0,03	0,02
	Nm	---	22	20	21	19	22	20	19	16	13	11	8
	eff.	---	0.82	0.78	0.72	0.70	0.61	0.56	0.52	0.45	0.43	0.40	0.37
RS - RT 40	kW	1.2	0,84	0,64	0,44	0,30	0,28	0,19	0,16	0,14	0,12	0,10	0,08
	Nm	54	52	54	52	45	52	46	43	41	40	39	36
	eff.	0.86	0.83	0.80	0.74	0.70	0.63	0.56	0.52	0.49	0.46	0.44	0.42
RS - RT 50	kW	2.1	1,5	1,1	0,75	0,52	0,51	0,35	0,28	0,25	0,19	0,17	0,12
	Nm	96	95	95	91	79	99	85	81	80	67	67	55
	eff.	0.86	0.85	0.81	0.76	0.72	0.65	0.58	0.56	0.54	0.47	0.46	0.42
RS - RT 60	kW	3.2	2,4	1,9	1,4	1,0	0,87	0,56	0,43	0,40	0,32	0,28	0,19
	Nm	150	150	163	166	161	175	152	135	130	125	115	94
	eff.	0.87	0.85	0.83	0.75	0.76	0.68	0.64	0.61	0.55	0.53	0.48	0.47
RS - RT 70	kW	4.5	3,2	2,4	1,7	1,3	1,2	0,87	0,64	0,53	0,42	0,38	0,30
	Nm	212	202	211	218	207	242	240	205	187	170	160	147
	eff.	0.88	0.86	0.83	0.79	0.77	0.70	0.65	0.62	0.59	0.54	0.50	0.46
RS - RT 85	kW	7.2	5,0	3,9	3,0	2,1	1,8	1,5	1,0	0,83	0,73	0,64	0,51
	Nm	338	320	350	378	355	373	410	350	332	300	290	260
	eff.	0.88	0.86	0.84	0.80	0.78	0.71	0.66	0.67	0.67	0.55	0.53	0.48
RS - RT 110	kW	---	9,8	8,0	5,7	4,4	3,7	2,7	2,3	1,9	1,7	1,5	0,94
	Nm	---	635	720	745	745	795	780	780	690	765	715	500
	eff.	---	0.87	0.85	0.82	0.79	0.73	0.68	0.64	0.62	0.59	0.57	0.50
RS 130	kW	---	14,9	11,7	8,4	6,5	5,1	4,1	3,1	2,8	2,1	1,8	1,3
	Nm	---	975	1070	1115	1115	1145	1215	1095	1145	960	890	805
	eff.	---	0.88	0.86	0.83	0.81	0.75	0.70	0.67	0.68	0.63	0.58	0.57
RS 150	kW	---	20,8	15,9	12,2	9,3	7,3	5,6	4,5	3,3	2,9	2,5	2,0
	Nm	---	1360	1470	1635	1625	1660	1740	1600	1370	1390	1290	1230
	eff.	---	0.88	0.87	0.84	0.82	0.77	0.73	0.69	0.69	0.64	0.61	0.58

VARVEL - RS & RT

RS-RT (700 min⁻¹)

TABELLA SELEZIONE
SELECTION TABLE
AUSWAHLTABELLE

RS RT	i =	5	7	10	15	20	28	40	49	56	70	80	100
	min ⁻¹	140	100	70	47	35	25	18	15	13	10	8.7	7
RS - RT 28	Kw	---	0,29	0,21	0,14	0,10	0,10	0,06	0,05	0,04	0,03	0,02	0,01
	Nm	---	23	23	22	21	24	21	20	17	13	11	8
	eff.	---	0.81	0.77	0.71	0.69	0.60	0.55	0.51	0.44	0.40	0.39	0.36
RS - RT 40	KW	1.00	0,74	0,54	0,39	0,26	0,24	0,17	0,14	0,12	0,10	0,09	0,07
	Nm	59	58	58	58	49	55	49	46	45	43	41	38
	eff.	0.85	0.82	0.79	0.73	0.68	0.59	0.53	0.50	0.48	0.44	0.42	0.39
RS - RT 50	KW	1.8	1,4	0,92	0,65	0,44	0,43	0,29	0,24	0,21	0,16	0,15	0,12
	Nm	106	110	100	99	86	106	91	87	83	70	72	62
	eff.	0.86	0.83	0.80	0.75	0.71	0.64	0.57	0.542	0.52	0.45	0.44	0.39
RS - RT 60	KW	2.8	2,0	1,6	1,1	0,87	0,73	0,49	0,35	0,34	0,26	0,24	0,17
	Nm	165	164	177	178	175	187	165	140	139	128	120	100
	eff.	0.87	0.84	0.81	0.77	0.74	0.67	0.62	0.59	0.54	0.51	0.46	0.44
RS - RT 70	KW	3.9	2,7	2,1	1,4	1,1	1,0	0,71	0,55	0,46	0,36	0,32	0,24
	Nm	234	216	233	231	225	256	245	220	197	176	167	150
	eff.	0.87	0.85	0.82	0.78	0.75	0.68	0.63	0.60	0.56	0.51	0.48	0.45
RS - RT 85	KW	6.2	4,6	3,5	2,5	1,9	1,5	1,2	0,93	0,78	0,59	0,56	0,44
	Nm	372	370	400	408	388	400	420	379	353	310	305	275
	eff.	0.87	0.85	0.83	0.79	0.76	0.69	0.65	0.61	0.59	0.55	0.50	0.46
RS - RT 110	kW	---	8,5	6,8	4,9	3,9	3,3	2,3	2,0	1,7	1,5	1,2	0,79
	Nm	---	700	780	795	815	890	820	840	770	815	720	515
	eff.	---	0.86	0.84	0.80	0.77	0.71	0.66	0.62	0.60	0.57	0.55	0.48
RS 130	kW	---	12,8	10,3	7,4	5,6	4,4	3,6	2,7	2,4	1,8	1,6	1,1
	Nm	---	1060	1200	1230	1215	1200	1320	1185	1215	1030	955	855
	eff.	---	0.87	0.85	0.81	0.80	0.72	0.68	0.65	0.66	0.61	0.56	0.55
RS 150	kW	---	18,0	13,7	10,6	8,1	6,2	4,9	3,8	3,0	2,6	2,3	1,7
	Nm	---	1475	1610	1805	1780	1790	1890	1710	1535	1500	1425	1275
	eff.	---	0.87	0.86	0.83	0.81	0.75	0.71	0.68	0.67	0.61	0.58	0.56

RA-TA $i=3.5$ (1400 min⁻¹)

VARVEL - RS & RT

TABELLA SELEZIONE
SELECTION TABLE
AUSWAHLTABELLE

SXA	i = min ⁻¹	3.5	6.3	8
XA63	KW	0.50	0.23	0.18
	Nm	12	10	9
	R ₂ [N]	390	450	450
XA71	KW	1.1	0.52	0.37
	Nm	26	22	20
	R ₂ [N]	490	560	560
XA80	KW	3.1	1.5	1.1
	Nm	68	65	60
	R ₂ [N]	610	700	700
XA100	KW	8.7	4.0	2.2
	Nm	235	163	136
	R ₂ [N]	1500	2500	2500

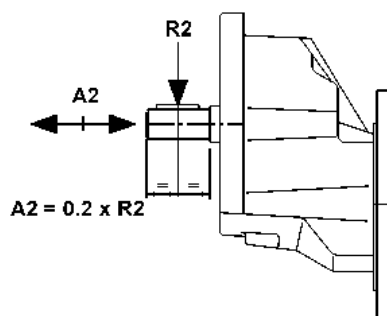

Dimensioni: pagina 44
Dimensions: page 44
Abmessungen: Seite 44

i = 3.5	i = i ₁ x i ₂ min ⁻¹	25	35	53	70	98	140	172	196	245	280	350
		il ₂	7	10	15	20	28	40	49	56	70	80
63/40	kW	0.55	0.40	0.28	0.20	0.19	0.13	0.11	0.10	0.06	0.05	0.03
	Nm	72	72	70	60	70	64	58	56	42	35	25
	eff.	0.78	0.75	0.70	0.63	0.56	0.50	0.46	0.44	0.41	0.40	0.35
63/50 71/50	kW	1.02	0.70	0.50	0.33	0.32	0.21	0.20	0.16	0.11	0.09	0.06
	Nm	135	127	125	105	125	105	115	100	80	70	50
	eff.	0.79	0.76	0.70	0.66	0.59	0.52	0.50	0.46	0.42	0.40	0.35
63/60 71/60 80/60	kW	1.53	1.18	0.83	0.57	0.53	0.33	0.27	0.23	0.19	0.15	0.10
	Nm	205	217	215	192	217	177	170	152	145	110	85
	eff.	0.80	0.77	0.72	0.70	0.61	0.57	0.54	0.49	0.45	0.38	0.36
71/70 80/70	kW	1.96	1.48	1.08	0.77	0.72	0.50	0.43	0.36	0.30	0.26	0.19
	Nm	265	275	285	260	310	270	270	235	225	200	180
	eff.	0.81	0.78	0.74	0.71	0.64	0.57	0.54	0.49	0.45	0.41	0.39
71/85 80/85	kW	3.14	2.39	1.77	1.37	1.11	0.80	0.65	0.58	0.49	0.40	0.26
	Nm	430	450	475	470	475	445	420	410	390	340	250
	eff.	0.82	0.79	0.75	0.72	0.64	0.58	0.55	0.53	0.48	0.44	0.40
80/110 100/110	kW	6.02	4.63	3.58	2.61	2.18	1.60	1.27	1.12	0.86	0.86	0.54
	Nm	835	895	950	910	960	950	850	820	750	740	540
	eff.	0.83	0.81	0.74	0.73	0.66	0.62	0.57	0.55	0.52	0.45	0.42
100/130	kW	7.0	6.8	5.5	3.8	3.1	2.3	1.7	1.5	1.3	1.1	0.8
	Nm	975	1320	1495	1350	1430	1380	1300	1250	1200	1080	880
	eff.	0.83	0.81	0.77	0.75	0.67	0.63	0.64	0.62	0.60	0.50	0.48
100/150	kW	7.9	7.8	7.5	5.7	4.5	3.3	2.7	2.4	1.8	1.6	1.0
	Nm	1115	1535	2090	2060	2130	2050	2040	2025	1700	1459	1200
	eff.	0.84	0.82	0.79	0.76	0.69	0.66	0.64	0.62	0.60	0.52	0.50

VARVEL - RS & RT

RA-TA $i=6.3$ (1400 min⁻¹)

TABELLA SELEZIONE
SELECTION TABLE
AUSWAHLTABELLE

i = 6.3	$i = i_1 \times i_2$	44	63	95	126	176	252	309	353	441	504	630
	min ⁻¹	32	22	15	11	8	5.5	4.6	4	3.2	2.8	2.2
	$i l_2$	7	10	15	20	28	40	49	56	70	80	100
63/40	KW	0.35	0.25	0.17	0.12	0.11	0.08	0.06	0.06	0.05	0.04	0.03
	Nm	79	78	74	63	69	63	57	55	53	51	46
	R ₂ [N]	0.76	0.72	0.67	0.60	0.52	0.45	0.43	0.39	0.35	0.34	0.31
63/50 71/50	KW	0.62	0.42	0.30	0.20	0.20	0.14	0.11	0.10	0.09	0.07	0.05
	Nm	145	133	130	113	138	115	108	100	92	89	72
	R ₂ [N]	0.78	0.74	0.67	0.63	0.55	0.48	0.45	0.42	0.36	0.36	0.31
63/60 71/60 80/60	KW	0.92	0.74	0.52	0.40	0.35	0.23	0.16	0.16	0.11	0.10	0.08
	Nm	218	237	235	230	238	210	160	175	141	130	122
	R ₂ [N]	0.79	0.75	0.70	0.67	0.57	0.53	0.49	0.45	0.42	0.37	0.35
71/70 80/70	KW	1.2	0.95	0.68	0.50	0.44	0.32	0.26	0.23	0.18	0.17	0.12
	Nm	289	310	310	292	320	259	272	254	221	210	190
	R ₂ [N]	0.80	0.76	0.71	0.68	0.60	0.54	0.50	0.46	0.42	0.37	0.36
71/85 80/85	KW	2.0	1.6	1.1	0.84	0.69	0.53	0.43	0.37	0.28	0.26	0.22
	Nm	490	526	516	495	501	500	466	449	391	380	345
	R ₂ [N]	0.80	0.77	0.72	0.69	0.60	0.55	0.51	0.50	0.46	0.42	0.36
80/110 100/110	KW	4.3	3.2	2.4	1.8	1.6	1.1	1.0	0.80	0.66	0.51	0.32
	Nm	1030	1100	1150	1100	1170	1110	1100	995	950	780	550
	R ₂ [N]	0.81	0.79	0.74	0.71	0.63	0.57	0.53	0.52	0.48	0.45	0.39

RA-TA i=8 (1400 min⁻¹)

VARVEL - RS & RT

TABELLA SELEZIONE
SELECTION TABLE
AUSWAHLTABELLE

i = 8	i = i ₁ x i ₂	56	80	120	160	224	320	392	448	560	640	800
	min ⁻¹	25	18	12	9	6	4	3.5	3	2.5	2.2	1.75
	il ₂	7	10	15	20	28	40	49	56	70	80	100
63/40	kW	0.32	0.23	0.16	0.11	0.11	0.08	0.06	0.05	0.03	0.03	0.02
	Nm	93	89	84	72	85	75	69	59	45	38	27
	eff.	0.75	0.72	0.65	0.59	0.50	0.44	0.41	0.38	0.36	0.34	0.31
63/50 71/50	kW	0.58	0.41	0.28	0.20	0.18	0.13	0.10	0.09	0.06	0.05	0.03
	Nm	170	165	154	130	150	130	120	115	86	73	53
	eff.	0.77	0.73	0.67	0.61	0.55	0.47	0.45	0.41	0.36	0.37	0.31
63/60 71/60 80/60	kW	0.87	0.68	0.49	0.34	0.31	0.21	0.16	0.15	0.10	0.08	0.05
	Nm	260	280	275	240	270	235	220	200	155	125	92
	eff.	0.78	0.75	0.69	0.65	0.57	0.51	0.50	0.43	0.41	0.37	0.35
71/70 80/70	kW	1.26	0.88	0.63	0.44	0.48	0.28	0.24	0.20	0.16	0.12	0.05
	Nm	380	365	360	325	440	320	320	275	245	200	145
	eff.	0.79	0.76	0.70	0.67	0.60	0.53	0.50	0.45	0.41	0.38	0.35
71/85 80/85	kW	1.76	1.42	1.07	0.85	0.65	0.48	0.40	0.33	0.26	0.20	0.13
	Nm	530	595	620	620	600	560	550	510	450	360	260
	eff.	0.79	0.77	0.71	0.67	0.60	0.54	0.52	0.50	0.45	0.41	0.37
80/110 100/110	kW	3.42	2.75	1.97	1.52	1.29	0.97	0.73	0.64	0.52	0.43	0.27
	Nm	1045	1170	1180	1160	1200	1180	1020	980	920	850	550
	eff.	0.80	0.78	0.73	0.70	0.61	0.56	0.52	0.50	0.46	0.45	0.38
100/130	kW	3.3	3.0	3.2	2.3	1.8	1.2	1.1	0.9	0.7	0.7	0.5
	Nm	1000	1240	1840	1765	1760	1700	1660	1600	1435	1330	1160
	eff.	0.80	0.78	0.73	0.72	0.62	0.58	0.56	0.54	0.51	0.45	0.43
100/150	kW	3.7	3.4	3.6	3.4	2.7	2.0	1.7	1.4	1.1	1.0	0.8
	Nm	1130	1425	2150	2580	2675	2860	2550	2490	2110	1970	1855
	eff.	0.81	0.79	0.75	0.72	0.63	0.61	0.56	0.57	0.49	0.46	0.45

VARVEL - RS & RT

RS/RS-RT/RT (1400 min⁻¹)

TABELLA SELEZIONE
SELECTION TABLE
AUSWAHLTABELLE

RS/RS RT/RT	$i = i_1 \times i_2$	420	560	784	1120	1568	2240	2800	4000	5600	8000	10000
	min ⁻¹	3.3	2.5	1.8	1.25	0.9	0.6	0.5	0.35	0.25	0.17	0.14
	$i_1 =$	15	20	28	40	56	56	70	100	100	100	100
	$i_2 =$	28	28	28	28	28	40	40	40	40	56	80
28 / 28	W	32	25	21	16	13	9	8	6	3	1.8	1.3
	Nm	35	36	36	36	35	30	30	30	16	12	11
	eff.	0.38	0.37	0.32	0.30	0.25	0.21	0.20	0.18	0.14	0.12	0.13
28 / 40	W	75	60	46	34	30	22	22	14	11	5	3
	Nm	85	85	80	80	80	73	76	70	62	41	25
	eff.	0.39	0.37	0.33	0.31	0.25	0.21	0.18	0.18	0.15	0.14	0.12
28 / 50	W	133	106	91	74	60	36	36	28	20	10	6
	Nm	150	150	160	175	160	125	131	147	125	78	49
	eff.	0.39	0.37	0.33	0.31	0.25	0.22	0.19	0.19	0.16	0.14	0.12
28 / 60	W	197	157	132	91	91	67	54	30	32	16	10
	Nm	240	240	245	230	260	245	217	164	195	128	91
	eff.	0.42	0.40	0.35	0.33	0.27	0.23	0.21	0.20	0.16	0.14	0.13
40 / 70	W	298	249	198	157	119	86	72	60	42	24	16
	Nm	380	400	400	395	380	370	345	360	321	201	154
	eff.	0.44	0.42	0.38	0.33	0.30	0.27	0.25	0.22	0.20	0.15	0.14
40 / 85	W	447	372	276	224	180	138	120	90	72	39	26
	Nm	595	625	585	625	610	615	595	565	550	373	264
	eff.	0.46	0.44	0.40	0.35	0.32	0.28	0.26	0.23	0.20	0.17	0.15
50 / 110	W	865	756	579	453	382	292	235	163	128	82	51
	Nm	1190	1300	1300	1280	1350	1340	1210	1070	980	810	560
	eff.	0.48	0.45	0.42	0.37	0.33	0.30	0.27	0.24	0.20	0.18	0.16
RS 60 / 130	kW	1.5	1.1	0.75	0.55	0.55	0.37	0.25	0.25	0.25	0.25	0.25
	Nm	2015	1930	1670	1530	2015	1830	1410	1770	1850	1420	1225
	eff.	0.50	0.46	0.43	0.40	0.35	0.33	0.30	0.27	0.25	0.21	0.20
RS 70 / 150	kW	1.8	1.5	1.1	0.75	0.75	0.55	0.37	0.37	0.25	0.25	0.25
	Nm	2570	2830	2570	2460	2850	3020	2325	2875	2670	2135	1995
	eff.	0.52	0.50	0.46	0.43	0.39	0.36	0.33	0.31	0.27	0.23	0.22

MRS-MRT (1400 min⁻¹)

VARVEL - RS & RT

TABELLA SELEZIONE
SELECTION TABLE
AUSWAHLTABELLE

0.06 kW	min ⁻¹	i =	Nm	SF	kg	0.09 kW	min ⁻¹	i =	Nm	SF	kg
MRS-MRT28	200	7	2,4	>3	3,6	MRS-MRT 40	20	70	22	1,6	5,1
MRS-MRT 28	140	10	3,3	>3	3,6	MRS-MRT 40	18	80	25	1,3	5,1
MRS-MRT 28	93	15	4,7	>3	3,6	MRA-MTA 63/40	15	95	39	1,9	6,6
MRS-MRT 28	70	20	6,1	2,6	3,6	MRS-MRT 40	14	100	28	1,0	5,1
MRS-MRT 28	50	28	7,6	2,6	3,6	MRA-MTA 63/40	11	126	46	1,4	6,6
MRS-MRT 28	35	40	10	1,7	3,6	MRS-MRT 28 / 40	9,3	150	48	1,3	6,5
MRA-MTA 63/40	32	44	14	>3	6,5	MRA-MTA 63/40	8,0	176	56	1,2	6,6
MRS-MRT 28	29	49	11	1,5	3,6	MRS-MRT 28 / 40	7,0	200	60	1,3	6,5
MRS-MRT 28	25	56	12	1,3	3,6	MRA-MTA 63/40	5,5	252	70	0,9	6,6
MRA-MTA 63/40	22	63	19	>3	6,5	MRS-MRT 28 / 40	5,0	280	70	1,0	6,5
MRS-MRT 28	20	70	13	0,9	3,6	MRA-MTA 63/50	4,6	309	86	1,3	7,9
MRS-MRT 40	18	80	16	2,0	5,0	MRA-MTA 63/50	4,0	353	91	1,1	7,9
MRA-MTA 63/40	15	95	26	2,8	6,5	MRS-MRT 28 / 50	3,3	420	101	1,5	7,8
MRS-MRT 40	14	100	19	1,5	5,0	MRA-MTA 63/50	3,2	441	97	0,9	7,9
MRA-MTA 63/40	11	126	31	2,0	6,5	MRS-MRT 28 / 50	2,5	560	127	1,2	7,8
MRS-MRT 28 / 28	9,3	150	31	1,1	5,0	MRS-MRT 28 / 50	1,8	784	159	1,0	7,8
MRA-MTA 63/40	8,0	176	37	1,8	6,5	MRS-MRT 28 / 50	1,3	1120	213	0,8	7,8
MRS-MRT 28 / 28	7,0	200	30	0,8	5,0	MRS-MRT 28 / 60	0,9	1568	260	1,0	11
MRA-MTA 63/40	5,5	252	46	1,4	6,5	MRS-MRT 40 / 70	0,6	2240	371	1,0	15
MRS-MRT 28 / 28	5,0	280	35	0,8	5,0	MRS-MRT 40 / 85	0,5	2800	447	1,3	19
MRA-MTA 63/40	4,6	309	54	1,0	6,5	MRS-MRT 40 / 85	0,4	4000	565	1,0	19
MRA-MTA 63/40	4,0	353	56	1,0	6,5	MRS-MRT 40 / 85	0,3	5600	688	0,8	19
MRS-MRT 28 / / 40	3,3	420	67	1,3	6,4						
MRA-MTA 63/50	3,2	441	65	1,4	7,8	0,12 kW	min ⁻¹	i =	Nm	SF	kg
MRA-MTA 63/50	2,8	504	74	1,2	7,8	MRS-MRT 28	200	7	4,8	>3	4,8
MRS-MRT 28 / / 40	2,5	560	85	1,0	6,4	MRS-MRT 28	140	10	6,6	2,7	4,8
MRA-MTA 63/50	2,2	630	80	0,9	7,8	MRS-MRT 28	93	15	9,5	1,9	4,8
MRS-MRT 28 / 50	1,8	784	106	1,5	7,7	MRS-MRT 28	70	20	12	1,3	4,8
MRS-MRT 28 / 50	1,3	1120	142	1,2	7,7	MRS-MRT 28	50	28	15	1,3	4,8
MRS-MRT 28 / 50	0,9	1560	160	1,0	7,7	MRS-MRT 40	35	40	0	2,1	6,2
MRS-MRT 28 / 60	0,6	2240	211	1,2	10	MRA-MTA 63/40	32	44	27	2,9	7,7
MRS-MRT 28 / 60	0,5	2800	241	0,9	10	MRS-MRT 40	29	49	23	1,8	6,2
MRS-MRT 40 / 70	0,4	4000	360	1,0	15	MRS-MRT 40	25	56	26	1,5	6,2
MRS-MRT 40 / 70	0,3	5600	458	0,7	15	MRA-MTA 63/40	22	63	37	2,1	7,7
MRS-MRT 40 / 85	0,2	8000	557	0,7	19	MRS-MRT 40	20	70	30	1,2	6,2
MRS-MRT 40 / 85	0,1	10000	614	0,4	19	MRS-MRT 40	18	80	33	1,0	6,2
						MRA-MTA 63/40	15	95	52	1,4	7,7
0,09 kW	min ⁻¹	i =	Nm	SF	kg	MRS-MRT 50	14	100	38	1,1	7,5
MRS-MRT 28	200	7	3,6	>3	3,7	MRA-MTA 63/40	11	126	62	1,0	7,7
MRS-MRT 28	140	10	5,0	>3	3,7	MRS-MRT 28 / 40	9,3	150	64	1,4	7,6
MRS-MRT 28	93	15	7,1	2,5	3,7	MRA-MTA 63/40	8,0	176	75	0,9	7,7
MRS-MRT 28	70	20	9,1	1,8	3,7	MRS-MRT 28 / 40	7,0	200	77	1,0	7,6
MRS-MRT 28	50	28	11	1,8	3,7	MRA-MTA 63//50	5,5	252	99	1,2	9,0
MRS-MRT 28	35	40	15	1,1	3,7	MRS-MRT 28 / 40	5,0	280	94	0,8	7,6
MRA-MTA 63/40	32	44	21	>3	6,6	MRA-MTA 63//50	4,6	309	114	0,9	9,0
MRS-MRT 28	29	49	17	1,0	3,7	MRS-MRT 28 / 50	3,3	420	134	1,2	8,9
MRS-MRT 40	25	56	20	2,1	5,1	MRS-MRT 28 / 50	2,5	560	170	0,9	8,9
MRA-MTA 63/40	22	63	28	2,8	6,6	MRS-MRT 28 / 60	1,8	784	225	1,1	12

VARVEL - RS & RT

MRS-MRT (1400 min⁻¹)

TABELLA SELEZIONE
SELECTION TABLE
AUSWAHLTABELLE

0,12 kW	min ⁻¹	i =	Nm	SF	kg	0,25 kW	min ⁻¹	i =	Nm	SF	kg
MRS-MRT 28 / 60	1,3	1120	303	0,8	12	MRS-MRT 60	14	100	88	1,0	12
MRS-MRT 40 / 70	0,9	1568	385	1,0	16	MRA-MTA 71/60	11	126	144	1,6	15
MRS-MRT 40 / 85	0,6	2240	513	1,2	20	MRS-MRT 40 / 70	9,3	150	146	1,5	18
MRS-MRT 40 / 85	0,5	2800	596	1,0	20	MRA-MTA 71/60	8,0	176	171	1,4	15
MRS-MRT 40 / 85	0,4	4000	753	0,8	20	MRS-MRT 40 / 70	7,0	200	188	1,5	18
						MRA-MTA 71/70	5,5	252	232	1,3	18
						MRS-MRT 40 / 70	5,0	280	224	1,5	18
0,18 kW	min ⁻¹	i =	Nm	SF	kg	MRA-MTA 71/70	4,6	309	263	1,0	18
MRS-MRT 28	200	7	7,2	2,5	5,4	MRA-MTA 71/70	4,0	353	277	0,9	18
MRS-MRT 28	140	10	9,9	1,8	5,4	MRS-MRT 40 / 70	3,3	420	315	1,2	18
MRS-MRT 28	93	15	14	1,3	5,4	MRS-MRT 40 / 70	2,5	560	401	1,0	18
MRS-MRT 28	70	20	18	0,8	5,4	MRS-MRT 40 / 85	1,8	784	535	1,1	22
MRS-MRT 40	50	28	23	2,1	6,8	MRS-MRT 50 / 110	1,3	1120	707	1,8	46
MRS-MRT 40	35	40	30	1,4	6,8	MRS-MRT 50 / 110	0,9	1568	882	1,5	46
MRA-MTA 63/40	32	44	41	1,9	8,3	MRS-MRT 50 / 110	0,6	2240	1146	1,2	46
MRS-MRT 40	29	49	35	1,2	6,8	MRS-MRT 50 / 110	0,5	2800	1289	0,9	46
MRS-MRT 40	25	56	39	1,0	6,2						
MRA-MTA 63/40	22	63	56	1,4	8,3	0,37 kW	min ⁻¹	i =	Nm	SF	kg
MRS-MRT 50	20	70	46	1,4	8,1	MRS-MRT 40	280	5	11	>3	8,7
MRS-MRT 50	18	80	51	1,1	8,1	MRS-MRT 40	200	7	15	3,0	8,7
MRA-MTA 63/40	15	95	78	0,9	8,3	MRS-MRT 40	140	10	21	2,2	8,7
MRS-MRT 50	14	100	43	0,8	8,1	MRS-MRT 40	93	15	30	1,5	8,7
MRA-MTA 63/50	11	126	97	1,2	9,6	MRS-MRT 40	70	20	38	1,0	8,7
MRS-MRT 28 / 50	9,3	150	93	1,6	9,5	MRS-MRT 40	50	28	48	1,0	8,7
MRA-MTA 63/50	8,0	176	119	1,2	9,6	MRS-MRT 50	35	40	65	1,1	10
MRS-MRT 28 / 50	7,0	200	120	1,1	9,5	MRA-MTA 71/50	32	44	87	1,7	13
MRS-MRT 28 / 50	5,0	280	141	1,1	9,5	MRS-MRT 50	29	49	77	1,0	10
MRS-MRT 28 / 60	3,3	420	217	1,1	12	MRS-MRT 60	25	56	85	1,5	13
MRS-MRT 40 / 70	2,5	560	289	1,4	16	MRA-MTA 71/50	22	63	118	1,1	13
MRS-MRT 40 / 70	1,8	784	366	1,1	16	MRS-MRT 60	20	70	97	1,3	13
MRS-MRT 40 / 85	1,3	1120	481	1,3	21	MRS-MRT 60	18	80	107	1,0	13
MRS-MRT 40 / 85	0,9	1568	616	1,0	21	MRA-MTA 71/60	15	95	168	1,4	16
MRS-MRT 40 / 85	0,6	2240	770	0,8	21	MRS-MRT 70	14	100	130	1,0	15
						MRA-MTA 71/60	11	126	213	1,1	15
0,25 kW	min ⁻¹	i =	Nm	SF	kg	MRS-MRT 40 / 70	9,3	150	217	2,1	18
MRS-MRT 40	280	5	7,5	>3	8,3	MRA-MTA 71/60	8,0	176	253	0,9	15
MRS-MRT 40	200	7	10	>3	8,3	MRS-MRT 40 / 70	7,0	200	278	1,3	18
MRS-MRT 40	140	10	14	>3	8,3	MRA-MTA 71/70	5,5	252	343	0,9	18
MRS-MRT 40	93	15	20	2,2	8,3	MRS-MRT 40 / 70	5,0	280	332	1,1	18
MRS-MRT 40	70	20	26	1,5	8,3	MRS-MRT 40 / 85	3,3	420	488	1,2	23
MRS-MRT 40	50	28	32	1,5	8,3	MRS-MRT 40 / 85	2,5	560	622	1,0	23
MRS-MRT 40	35	40	42	1,0	8,3	MRS-MRT 50 / 110	1,3	1120	1046	1,2	47
MRA-MTA 71/50	32	44	59	2,5	12	MRS-MRT 50 / 110	0,9	1568	1306	1,1	47
MRS-MRT 50	29	49	52	1,5	9,6						
MRS-MRT 50	25	56	57	1,3	9,6	0,55 kW	min ⁻¹	i =	Nm	SF	kg
MRA-MTA 71/50	22	63	80	1,7	12	MRS-MRT 40	280	5	16	2,8	10,7
MRS-MRT 50	20	70	63	1,0	9,6	MRS-MRT 50	200	7	23	>3	12
MRS-MRT 60	18	80	72	1,5	12	MRS-MRT 50	140	10	32	2,4	12
MRA-MTA 71/50	95	95	109	1,2	12						

MRS-MRT (1400 min⁻¹)

VARVEL - RS & RT

TABELLA SELEZIONE
SELECTION TABLE
AUSWAHLTABELLE

0,55 kW	min ⁻¹	i =	Nm	SF	kg	1,1 kW	min ⁻¹	i =	Nm	SF	kg
MRS-MRT 50	93	15	44	1,7	12	MRS-MRT 60	200	7	45	2,5	19
MRS-MRT 50	70	20	57	1,1	12	MRS-MRT 60	140	10	63	2,1	19
MRS-MRT 50	50	28	75	1,1	12	MRS-MRT 60	93	15	91	1,4	19
MRS-MRT 60	35	40	99	1,4	15	MRS-MRT 60	70	20	116	1,1	19
MRA-MTA 80/60	32	44	130	1,7	19	MRS-MRT 70	50	28	158	1,4	21
MRS-MRT 60	29	49	114	1,1	15	MRS-MRT 70	35	40	213	1,1	21
MRS-MRT 60	25	56	126	1,0	15	MRA-MTA 80/70	32	44	264	1,1	25
MRA-MTA 80/60	22	63	177	1,2	19	MRS-MRT 85	29	49	246	1,3	26
MRS-MRT 70	20	70	155	1,1	18	MRS-MRT 85	25	56	286	1,1	26
MRS-MRT 70	18	80	168	1,0	18	MRA-MTA 80/85	22	63	364	1,4	30
MRA-MTA 80/60	15	95	249	1,0	19	MRS-MRT 110	20	70	352	1,8	48
MRS-MRT 85	14	100	210	1,0	22	MRS-MRT 110	18	80	396	1,3	48
MRA-MTA 80/70	11	126	321	1,1	22	MRA-MTA 80/85	15	95	513	1,0	30
MRA-MTA 80/85	8,0	176	396	1,3	26	MRS-MRT 110	14	100	458	1,0	48
MRA-MTA 80/85	5,5	252	520	1,0	26	MRA-MTA 80/110	11	126	671	1,6	52
MRA-MTA 8 0/110	4,6	309	614	1,8	49	MRA-MTA 80/110	8,0	176	832	1,4	52
MRA-MTA 80/110	4,0	353	689	1,4	49	MRA-MTA 80/110	5,5	252	1078	1,0	52
MRS-MRT 50 / 110	3,3	420	756	1,1	49	MRA-MTA 80/110	4,6	309	1229	0,9	52
MRA-MTA 80/110	3,2	441	794	1,2	49	MRA 110/130	3,5	400	1681	1,0	94
MRA-MTA 80/110	2,8	504	851	0,9	49	MRS-MRT 60 / 130	3,3	420	1576	1,3	69
MRS-MRT 50 / 110	2,5	570	962	1,3	49	MRA 110/150	3,0	448	1916	1,3	99
MRS-MRT 50 / 110	1,8	784	1235	1,5	49	MRA 110/150	2,5	560	2059	1,0	99
						MRA 110/150	2,2	640	2209	0,9	99
						MRS-MRT 70 / 150	1,8	784	2706	0,9	102
0,75 kW	min ⁻¹	i =	Nm	SF	kg	1,5 kW	min ⁻¹	i =	Nm	SF	kg
MRS-MRT 50	200	5	23	>3	14	MRS-MRT 60	280	5	46	2,7	20
MRS-MRT 50	200	7	31	2,4	14	MRS-MRT 60	200	7	62	1,8	20
MRS-MRT 50	140	10	43	1,7	14	MRS-MRT 60	140	10	86	1,5	20
MRS-MRT 50	93	15	60	1,2	14	MRS-MRT 60	93	15	124	1,0	20
MRS-MRT 60	70	20	79	1,5	17	MRS-MRT 60	70	20	166	1,2	23
MRS-MRT 60	50	28	102	1,4	17	MRS-MRT 70	50	28	215	1,0	23
MRS-MRT 60	35	40	135	1,0	17	MRS-MRT 70	35	40	295	1,4	27
MRA-MTA 80/60	32	44	178	1,2	20	MRA-MTA 80 / 85	32	44	360	1,4	31
MRS-MRT 70	29	49	168	1,1	19	MRS-MRT 85	29	49	336	0,9	27
MRS-MRT 70	25	56	183	1,0	19	MRS-MRT 110	29	49	356	1,8	50
MRA-MTA 80/60	22	63	242	1,0	20	MRS-MRT 110	25	56	401	1,5	50
MRS-MRT 85	20	70	226	1,3	23	MRA-MTA 80 / 85	22	63	496	1,1	31
MRS-MRT 85	18	80	246	1,1	23	MRS-MRT 110	20	70	480	1,3	50
MRA-MTA 8 70	11	126	341	0,9	23	MRS-MRT 110	18	80	540	1,0	50
MRA-MTA 80/85	8,0	176	540	0,9	27	MRA-MTA 80/110	15	95	719	1,6	54
MRA-MTA 80/110	5,5	252	735	1,5	50	MRS130	14	100	624	1,2	64
MRA-MTA 80/110	4,6	309	838	1,3	50	MRA-MTA 80/110	11	126	915	1,2	54
MRA-MTA 80/110	4,0	353	939	1,1	50	MRA-MTA 80/110	8,0	176	1135	1,0	54
MRS-MRT 50 / 110	3,3	420	1031	1,2	50	MRA100/130	7,0	200	1269	1,0	71
MRA-MTA 80/110	3,2	441	1083	0,9	50	MRA100/130	6,3	224	1421	1,2	71
MRS-MRT 50 / 110	2,5	570	1289	1,0	50	MRA100/150	5,0	280	1490	1,1	101
						MRA100/150	3,5	400	2292	1,1	101
1,1 kW	min ⁻¹	i =	Nm	SF	kg						
MRS-MRT 60	200	5	34	>3	19						

VARVEL - RS & RT

MRS-MRT (1400 min⁻¹)

TABELLA SELEZIONE
SELECTION TABLE
AUSWAHLTABELLE

2,2 kW	min ⁻¹	i =	Nm	SF	kg	4kW	min ⁻¹	i =	Nm	SF	kg
MRA110/150	3,0	448	2613	1,0	106	MRS-MRT 110	70	20	453	1,4	65
						MRS-MRT 110	50	28	581	1,1	65
2,2 kW	min ⁻¹	i =	Nm	SF	kg	MRS130	35	40	829	1,4	79
MRS-MRT 70	280	5	92	1,9	28	MRS130	29	49	963	1,0	79
MRS-MRT 70	200	7	92	1,8	28	MRS130	25	56	1085	0,9	79
MRS-MRT 70	140	10	129	1,4	28	MRS150	25	56	1115	1,3	109
MRS-MRT 70	93	15	187	1,0	28	MRS150	20	70	1299	0,9	109
MRS-MRT 85	70	20	246	1,3	33	MRA110/130	20	70	1433	0,9	86
MRS-MRT 85	50	28	319	1,0	33	MRA110/150	18	80	1724	0,9	116
MRS-MRT 110	35	40	438	1,6	55	MRA110/150	14	98	1845	1,2	116
MRS-MRT 110	29	49	522	1,2	55	MRA110/150	12	120	2456	0,9	116
MRS-MRT 110	25	56	588	1,0	55						
MRS-MRT 110	20	70	704	0,9	55	5,5 kW	min ⁻¹	i =	Nm	SF	kg
MRS130	18	80	756	1,1	69	MRS-MRT 110	200	7	231	2,3	79
MRS150	14	100	945	1,2	99	MRS-MRT 110	140	10	326	1,6	79
MRA100/130	14	98	985	1,5	78	MRS-MRT 110	93	15	473	1,2	79
MRA100/130	12	125	1369	1,3	78	MRS-MRT 110	70	20	623	1,0	79
MRA100/130	10	140	1324	1,0	78	MRS130	50	28	809	1,4	93
MRA100/130	8,9	160	1729	1,0	78	MRS130	35	40	1141	1,0	93
MRA100/150	7,0	200	1861	1,1	108	MRS150	29	49	1342	1,1	123
MRA100/150	6,3	230	2175	1,2	108	MRA110/130	27	53	1531	1,0	100
						MRS150	25	56	1534	0,9	123
3 kW	min ⁻¹	i =	Nm	SF	kg						
MRS-MRT 70	280	5	91	1,9	30	7,5 kW	min ⁻¹	i =	Nm	SF	kg
MRS-MRT 70	200	7	126	1,3	30	MRS-MRT 110	200	7	315	1,7	88
MRS-MRT 70	140	10	176	1,0	30	MRS-MRT 110	140	10	445	1,2	88
MRS-MRT 85	93	15	255	1,1	35	MRS-MRT 110	93	15	645	0,9	88
MRS-MRT 85	70	20	336	1,1	35	MRS130	93	15	652	1,5	102
MRS-MRT 110	50	28	435	1,5	57	MRS 130	70	20	860	1,1	102
MRS-MRT 110	35	40	598	1,2	57	MRS130	50	28	1103	1,0	102
MRS-MRT 110	29	49	712	0,9	57	MRS150	35	40	1576	1,1	132
MRS130	29	49	722	1,3	71	MRA110/130	26	53	1041	,4	109
MRS130	25	56	814	1,2	71	MRA110/150	25	56	1036	1,1	139
MRS150	20	70	974	1,3	101						
MRA100/130	20	70	1074	1,3	78	11 kW	min ⁻¹	i =	Nm	SF	kg
MRS150	18	80	1064	1,1	101	MRS150	200	7	467	2,3	148
MRA100/130	18	80	1277	1,0	78	MRS150	140	10	660	1,9	148
MRA100/130	14	98	1344	1,1	78	MRS150	93	15	968	1,5	148
MRS150	14	100	1289	0,9	101	MRS150	70	20	1261	1,1	148
MRA100/130	12	120	1793	1,0	78						
MRA100/150	10	140	1891	1,1	108	15 kW	min ⁻¹	i =	Nm	SF	kg
MRA100/150	8,9	160	2357	1,1	108	MRS150	200	7	637	1,7	158
						MRS150	140	10	900	1,4	158
4kW	min ⁻¹	i =	Nm	SF	kg	MRS150	93	15	1320	1,1	158
MRS-MRT 85	280	5	122	2,3	43						
MRS-MRT 85	200	7	168	1,5	43						
MRS-MRT 85	140	10	235	1,1	43						
MRS-MRT 110	93	15	344	1,6	65						

**MOTORI ELETTRICI
ELECTRIC MOTORS
ELEKTROMOTOREN**

VARVEL - RS & RT

**DIMENSIONI DI INGOMBRO
OVERALL DIMENSIONS
ABMESSUNGEN**

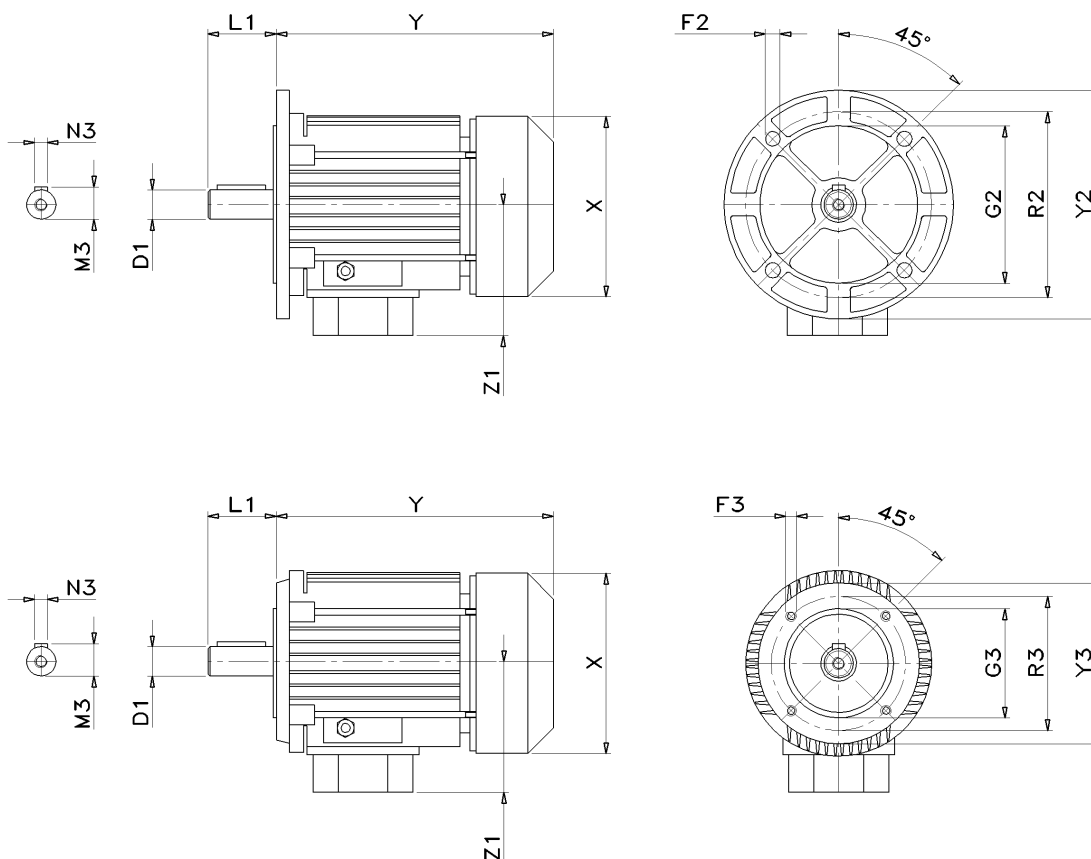

IEC MOTOR	56	63	71	80	90 S / L	100 / 112	132 S / M	160 M / L
D _{1(j6)} x L ₁	9 x 20	11 x 23	14 x 30	19 x 40	24 x 50	28 x 60	38 x 80	42 x 110
F ₂	7	9	9	11	11	14	14	18
F ₃	M,5	M,5	M,6	M,6	M,8	M,8	M,10	M,12
G _{2(j6)}	80	95	110	130	130	180	230	250
G _{3(j6)}	50	60	70	80	95	110	130	180
M ₃	10,4	12,8	16,3	21,8	27,3	31,3	41,3	45,3
N ₃	3	4	5	6	8	8	8	8
R ₂	100	115	130	165	165	215	265	300
R ₃	65	75	85	100	115	130	165	215
X	110	123	140	159	176	195 / 219	258	315
Y	168	185	215	238	255 / 280	309 / 328	368 / 405	478 / 522
Y ₂	120	140	160	200	200	250	300	350
Y ₃	80	90	105	120	140	160	200	250
Z ₁	108	110	121	138	149	160 / 172	192	220
Peso Weights kg Gewicht	2,5	4,5	6,0	10,0	13,5	21 / 29	43 / 52	68 / 78

Dimensioni non impegnative

- Not binding dimensions

- unverbindliche Abmessungen

VARVEL - RS & RT

DIMENSIONI DI INGOMBRO
 OVERALL DIMENSIONS
 ABMESSUNGEN

RS

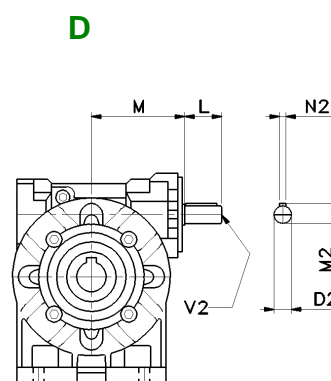
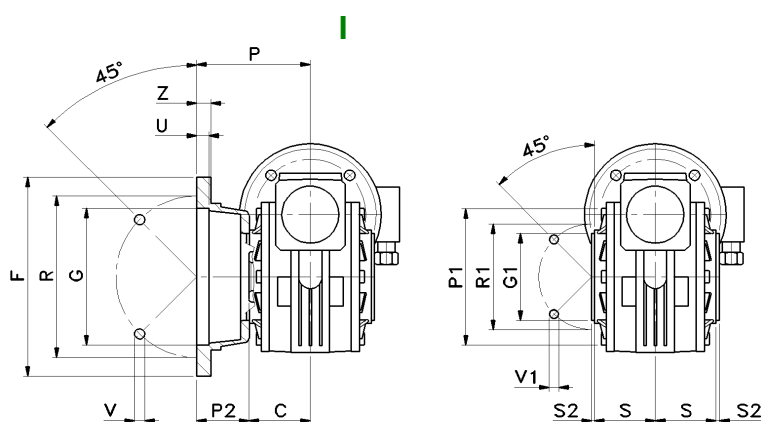
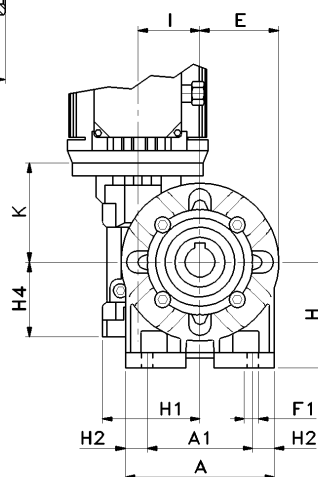
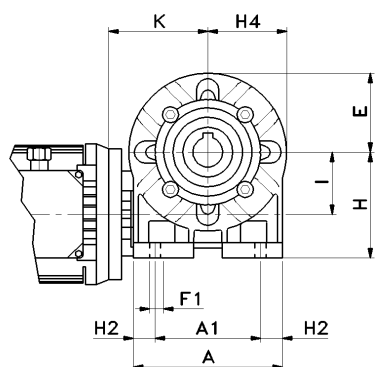
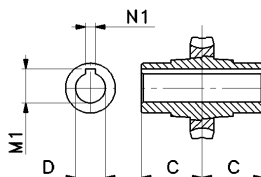
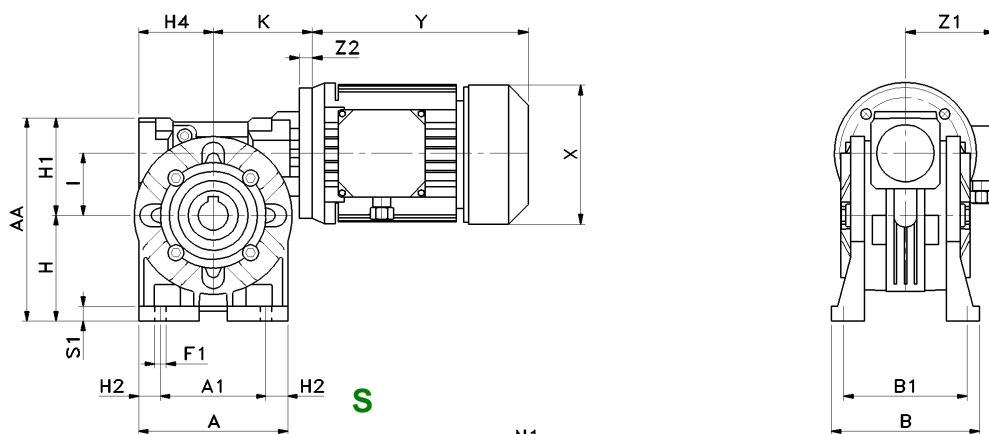

FL

PC

RS

RS

VARVEL - RS & RT

DIMENSIONI DI INGOMBRO
OVERALL DIMENSIONS
ABMESSUNGEN

RS	28	40	50	60	70	85	110	130	150
A	70	100	120	138	158	193	250	286	336
A ₁	52	70	85	95	120	140	200	235	260
AA	99	138	163	192	221	252	333	400	454
B	78	102	119	136	140	168	200	230	250
B ₁	66	84	99	111	116	140	162	190	210
C	30	41	49	60	60	61	77,5	90	105
D ^(H7)	14	19	24	25	28	32	42	48	55
D* ^(H7)	---	18	25	---	30	35	---	---	---
D ₂ ^(h6)	9	11	14	19	19	24	28	38	42
E	34	50	61	70	80	98	125	143	168
F	70	140	160	180	200	200	250	300	350
F ₁	5,5	7	9	11	11	13	14	15	19
G ^(H8)	40	95	110	115	130	130	180	230	250
G ₁ ^(f8)	42	60	70	70	80	110	130	180	180
H	52	71	85	100	115	135	172	200	230
H ₁	47	67	78	92	106	117	161	200	224
H ₂	9	15	17,5	21,5	19	26,5	25	25,5	38
H ₄	40	50	60	72	86	103	139	159	183
I	28	40	50	60	70	85	110	130	150
K	57,5	70,5	83-88*	93-94*	117-118*	134-137*	151-153*	165-166*	191-211*
L	20	23	30	40	40	50	60	80	100
M	50	65	75	87	110	123,5	146	166	195
M ₁	16,3	21,8	27,3	28,3	31,3	35,3	45,3	51,8	59,3
M ₂	10,2	12,5	16	22,5	22,5	27	31	41	45
N ₁	5	6	8	8	8	10	12	14	16
N ₂	3	4	5	6	6	8	8	10	12
P	49	82	91,5	116	111	100	150	150	160
P ₁	67	94	100	102	118	150	200	234	250
P ₂	19	41	42,5	56	51	39	72,5	60	55
R	56	115	130	150	165	165	215	265	300
R ₁	56	83	85	85	100	130	165	215	215
S	32	38	49	57,5	57	56,5	74,5	87	102
S ₁	6	9	12	12	14	15	17	19	20
S ₂	-3	2	2,5	2,5	3	3	2,5	5	5
U	4	6	10	10	12	6	5	5	6
V	6,5 (4)	9 (4)	9 (4)	11 (4)	13 (4)	13 (4)	15 (8)	15 (8)	19 (8)
V ₁	M6x6 (4)	M6x9 (4)	M8x12 (4)	M8x15 (8)	M8x18 (8)	M10x20 (8)	M12x21 (8)	M12x24 (8)	M14x30 (8)
V ₂	M4x10	M4x10	M6x15	M8x20	M8x20	M8x20	M8x20	M10x22	M12x25
Z	6	10	10	11	14	14	16	18	20

D* - Foro a richiesta

- Bore on demand

- auf Anfrage

V₁ - 90° per RS28

- 90° for RS28

- 90° für RS28

(*) - IEC71-B14 (FRS50) - IEC71-B14 (FRS60) - IEC 80-B14 (FRS70) - IEC 90-B14 (FRS85)

(*) - IEC100/112-B14 (FRS110) - IEC 100/112-B5 (FRS130) - IEC 160-B5 (FRS150)

Dimensioni motore: vedi pag. 28

- Motor dimensions: see page 28

- Abmessungen Motor: siehe Seite 28

Dimensioni non impegnative

- Not binding dimensions

- unverbindliche Abmessungen

VARVEL - RS & RT

DIMENSIONI DI INGOMBRO
OVERALL DIMENSIONS
ABMESSUNGEN

RA

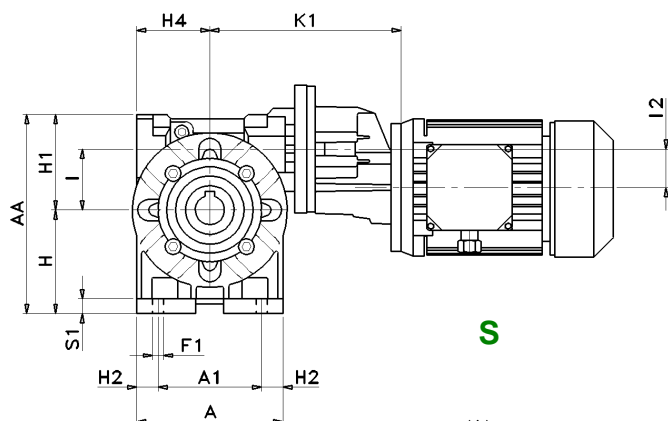

S

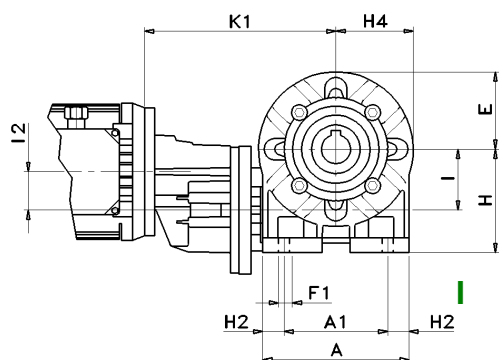
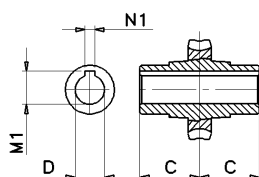
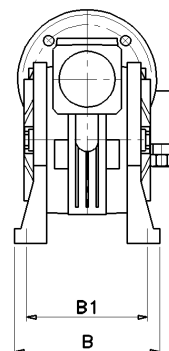

I

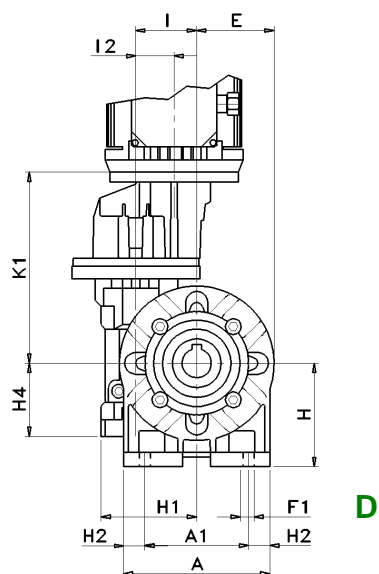

D

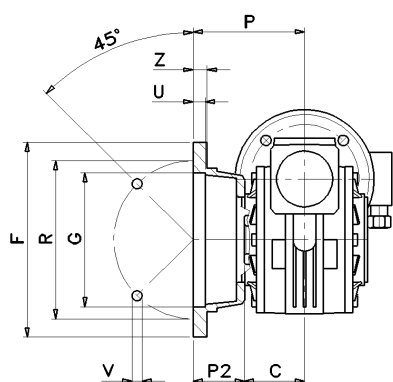

FL

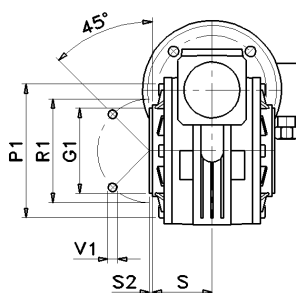

PC

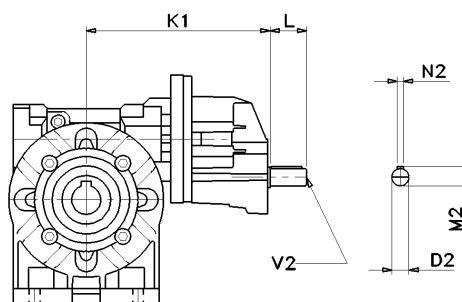

RA

RA

VARVEL - RS & RT

DIMENSIONI DI INGOMBRO
OVERALL DIMENSIONS
ABMESSUNGEN

RA	63/40	63/50	63/60	71/50	71/60	71/70	71/85	80/60	80/70	80/85	80/110	100/110	100/130	100/150
A	100	120	138	120	138	158	193	138	158	193	250	250	286	336
A ₁	70	85	95	85	95	120	140	95	120	140	200	200	235	260
AA	138	163	192	163	192	221	252	192	221	252	333	333	400	454
B	102	119	136	119	136	140	168	136	140	168	200	200	230	250
B ₁	84	99	111	99	111	116	140	111	116	140	162	162	190	210
C	41	49	60	49	60	60	61	60	60	61	77,5	77,5	90	105
D	19	24	25	24	25	28	32	25	28	32	42	42	48	55
D*	18	25	---	25	---	30	35	---	30	35	---	---	---	---
D ₂	11	11	11	14	14	14	14	19	19	19	19	24	24	24
E	50	61	70	61	70	80	98	70	80	98	125	125	143	168
F	140	160	180	160	180	200	200	180	200	200	250	250	300	350
F ₁	7	9	11	9	11	11	13	11	11	13	14	14	15	19
G	95	110	115	110	115	130	130	115	130	130	180	180	230	250
G ₁	60	70	70	70	70	80	110	70	80	110	130	130	180	180
H	71	85	100	85	100	115	135	100	115	135	172	172	200	230
H ₁	67	78	92	78	92	106	117	92	106	117	161	161	200	224
H ₂	15	17,5	21,5	17,5	21,5	19	26,5	21,5	19	26,5	25	25	25,5	38
H ₄	50	60	72	60	72	86	103	72	86	103	139	139	159	189
I	40	50	60	50	60	70	85	60	70	85	110	110	130	150
I ₂	32	32	32	40	40	40	40	50	50	50	50	63	63	63
K ₁	153,5	171	177	173 178*	183 188*	209 214*	224 229*	207	232,5	250,5	264,5	328	342	368
L	23	23	23	30	30	30	30	40	40	40	40	50	50	50
M ₁	21,8	27,3	28,3	27,3	28,3	31,3	35,3	28,3	31,3	35,3	45,3	45,3	51,8	59,3
M ₂	12,5	12,5	12,5	16	16	16	16	22,5	22,5	22,5	22,5	27	27	27
N ₁	6	8	8	8	8	8	10	8	8	10	12	12	14	16
N ₂	4	4	4	5	5	5	5	6	6	6	6	8	8	8
P	82	91,5	116	91,5	116	111	100	116	111	100	150	150	150	160
P ₁	94	100	102	100	102	118	150	102	118	150	200	200	234	250
P ₂	41	42,5	56	42,5	56	51	39	56	51	39	72,5	72,5	60	55
R	115	130	150	130	150	165	165	150	165	165	215	215	265	300
R ₁	83	85	85	85	85	100	130	85	100	130	165	165	215	215
S	38	49	57,5	49	57,5	57	56,5	57,5	57	56,5	74,5	74,5	87	102
S ₁	9	12	12	12	12	14	15	12	14	15	17	17	19	20
S ₂	2	2,5	2,5	2,5	2,5	3	3	2,5	3	3	2,5	2,5	5	5
U	6	10	10	10	10	12	6	10	12	6	5	5	5	6
V	9 (4)	9 (4)	11 (4)	9 (4)	11 (4)	13 (4)	13 (4)	11 (4)	13 (4)	13 (4)	15 (8)	15 (8)	15 (8)	19 (8)
V ₁	M6x9 (4)	M8x12 (4)	M8x15 (8)	M8x12 (4)	M8x15 (8)	M8x18 (8)	M10x2 0 (8)	M8x15 (8)	M8x18 (8)	M10x2 0 (8)	M12x2 1 (8)	M12x2 1 (8)	M12x2 4 (8)	M14x3 0 (8)
V ₂	M4x10	M4x10	M4x10	M6x15	M6x15	M6x15	M6x15	M8x20	M8x20	M8x20	M8x20	M8x20	M8x20	M8x20
Y ₁	105	105	105	120	120	120	120	140	140	140	140	140	200	200
Z	10	10	11	10	11	14	14	11	14	14	16	16	18	20

D* - Foro a richiesta

- Bore on demand

- auf Anfrage

V₁ - 90° per RS28

- 90° for RS28

- 90° für RS28

(*) - IEC71-B14 (FRA 71/....)

Dimensioni motore: vedi pag. 28

- Motor dimensions: see page 28

- Abmessungen Motor: siehe Seite 28

Dimensioni non impegnative

- Not binding dimensions

- unverbindliche Abmessungen

VARVEL - RS & RT

DIMENSIONI DI INGOMBRO
OVERALL DIMENSIONS
ABMESSUNGEN

RS/RS

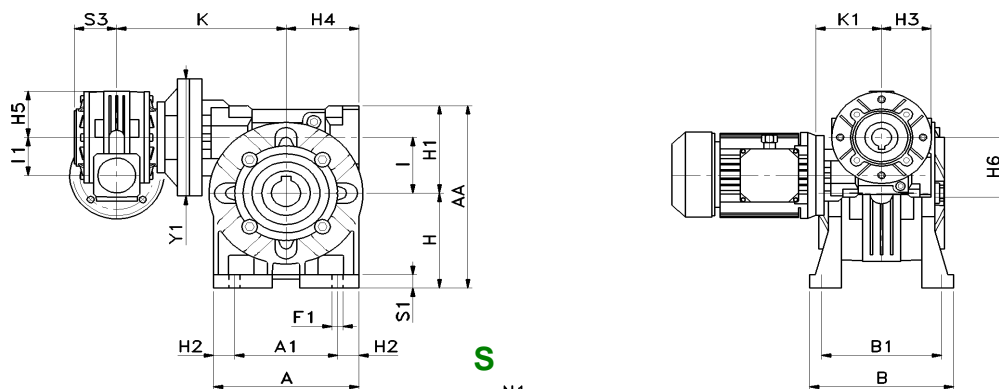

S

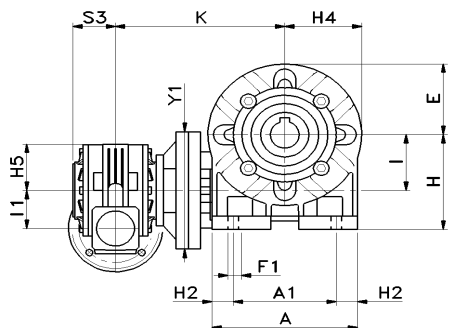
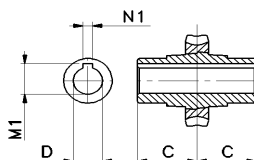

I

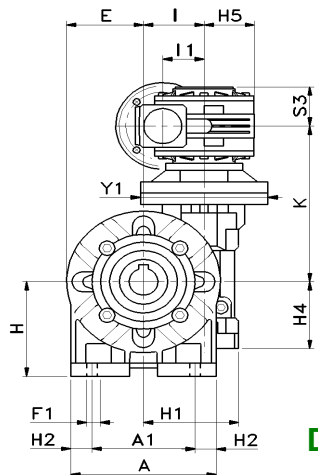

D

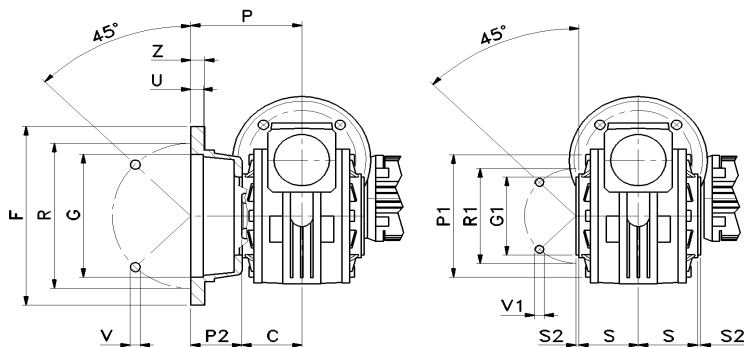

FL

PC

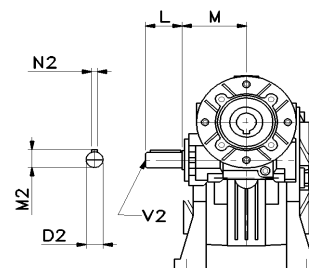

RS/RS

RS/RS

VARVEL - RS & RT

DIMENSIONI DI INGOMBRO
OVERALL DIMENSIONS
ABMESSUNGEN

RS/RS	28/28	28/40	28/50	28/60	40/70	40/85	50/110	60/130	70/150
A	70	100	120	138	158	193	250	286	336
A ₁	52	70	85	95	120	140	200	235	260
AA	99	138	163	192	221	252	333	400	454
B	78	102	119	136	140	168	200	230	250
B ₁	66	84	99	111	116	140	162	190	210
C	30	41	49	60	60	61	77,5	90	105
D ^(H7)	14	19	24	25	28	32	42	48	55
D* ^(H7)	---	18	25	---	30	35	---	---	---
D ₂ ^(h6)	9	9	9	9	11	11	14	38	42
E	34	50	61	70	80	98	125	143	168
F	70	140	160	180	200	200	250	300	350
F ₁	5,5	7	9	11	11	13	14	15	19
G ^(H8)	40	95	110	115	130	130	180	230	250
G ₁ ^(f8)	42	60	70	70	80	110	130	180	180
H	52	71	85	100	115	135	172	200	230
H ₁	47	67	78	92	106	117	161	200	224
H ₂	9	15	17,5	21,5	19	26,5	25	25,5	38
H ₃	40	40	40	40	50	50	60	72	86
H ₄	40	50	60	72	86	103	139	159	189
H ₅	34	34	34	34	50	50	61	70	80
H ₆	47	47	47	47	67	67	78	92	106
I	28	40	50	60	70	85	110	130	150
I ₂	28	28	28	28	40	40	50	60	70
K	99,5	116	138,5	146	182	199	246	246	300
K ₁	57,5	57,5	57,5	57,5	70,5	70,5	83 - 88*	93 - 94*	117-118*
L	20	20	20	20	23	23	30	40	40
M	50	50	50	50	65	65	75	87	110
M ₁	16,3	21,8	27,3	28,3	31,3	35,3	45,3	51,8	59,3
M ₂	10,2	10,2	10,2	10,2	12,5	12,5	16	22,5	22,5
N ₁	5	6	8	8	8	10	12	14	16
N ₂	3	3	3	3	4	4	5	6	6
P	49	82	91,5	116	111	100	150	150	160
P ₁	67	94	100	102	118	150	200	234	250
P ₂	19	41	42,5	56	51	39	72,5	60	55
R	56	115	130	150	165	165	215	265	300
R ₁	56	83	85	85	100	130	165	215	215
S	32	38	49	57,5	57	56,5	74,5	87	102
S ₁	6	9	12	12	14	15	17	19	20
S ₂	-3	2	2,5	2,5	3	3	2,5	5	5
S ₃	30	30	30	30	41	41	49	60	60
U	4	6	10	10	12	6	5	5	6
V	6,5 (4)	9 (4)	9 (4)	11 (4)	13 (4)	13 (4)	15 (8)	15 (8)	19 (8)
V ₁	M6x6 (4)	M6x9 (4)	M8x12 (4)	M8x15 (8)	M8x18 (8)	M10x20 (8)	M12x21 (8)	M12x24 (8)	M14x30 (8)
V ₂	M4x10	M4x10	M4x10	M4x10	M4x10	M4x10	M6x15	M8x20	M8x20
Y ₁	80	80	80	90	115	115	110	180	200
Z	6	10	10	11	14	14	16	18	20

D* - Foro a richiesta

- Bore on demand

- auf Anfrage

V₁ - 90° per RS28

- 90° for RS28

- 90° für RS28

(*) - IEC71-B14 (FRS50) - IEC71-B14 (FRS60) - IEC 80-B14 (FRS70)

Dimensioni motore: vedi pag, 28

- Motor dimensions: see page 28

- Abmessungen Motor: siehe Seite 28

Dimensioni non impegnative

- Not binding dimensions

- unverbindliche Abmessungen

VARVEL - RS & RT

DIMENSIONI DI INGOMBRO
OVERALL DIMENSIONS
ABMESSUNGEN

RS

VARIANTI COSTRUTTIVE
ALTERNATIVE MOUNTINGS
AUSFÜHRUNGSVARIANTEN

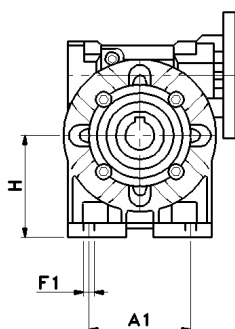
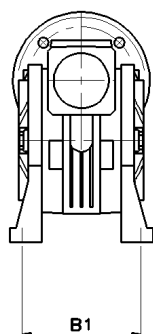

SA

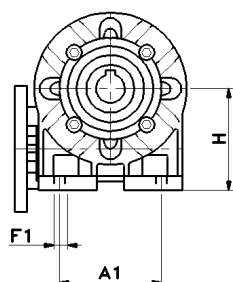

IA

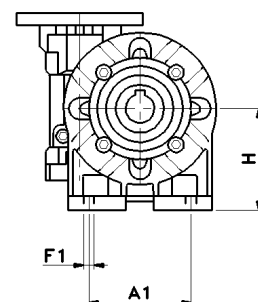

DA

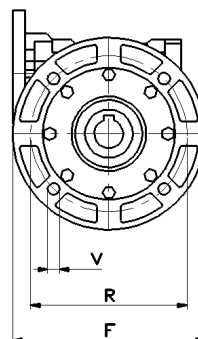
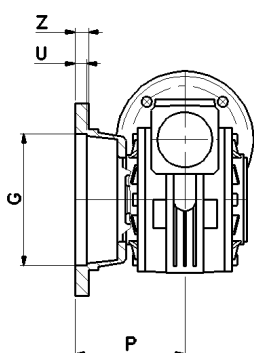

FA - FB - FR

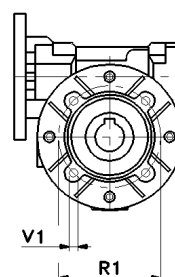
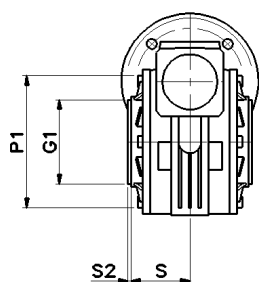

PA - PB

RS

VARIANTI COSTRUTTIVE
ALTERNATIVE MOUNTINGS
AUSFÜHRUNGSVARIANTEN

VARVEL - RS & RT

DIMENSIONI DI INGOMBRO
OVERALL DIMENSIONS
ABMESSUNGEN

RS	28	40	50	60	70	85	110	130	150
SA - IA - DA									
A ₁	---	52	63	---	---	140	---	---	---
B ₁	---	81	98,5	---	---	146	---	---	---
F ₁	---	8,5	9	---	---	11	---	---	---
H	---	72	82	---	---	142	---	---	---
FA									
F	80	105	125	165	165	---	---	---	---
G _(H8)	50	60	70	110	115	---	---	---	---
P	50,5	69	93	90	116	---	---	---	---
R	68	87	90	130	150	---	---	---	---
U	3,5	5	5	10	4,5	---	---	---	---
V	6,5 (4)	9 (4)	11 (4)	10,5 (4)	11 (4)	---	---	---	---
Z	7	8	10	15	10	---	---	---	---
FB									
F	---	120	---	180	---	210	270	---	---
G _(H8)	---	80	---	115	---	152	170	---	---
P	---	62	---	86	---	119,5	131,5	---	---
R	---	100	---	150	---	176	230	---	---
U	---	4	---	3,5	---	5	5	---	---
V	---	9 (4)	---	11 (4)	---	11 (4)	13 (4)	---	---
Z	---	9	---	12	---	14	18	---	---
FR									
F	---	---	---	---	160	---	---	---	---
G _(H8)	---	---	---	---	110	---	---	---	---
P	---	---	---	---	84,5	---	---	---	---
R	---	---	---	---	130	---	---	---	---
U	---	---	---	---	4,5	---	---	---	---
V	---	---	---	---	11 (4)	---	---	---	---
Z	---	---	---	---	14	---	---	---	---
PA									
G _{1 (H8)}	---	50	68	75	90	---	---	---	---
P ₁	---	95	110	104	125	---	---	---	---
R ₁	---	65	94	90	110	---	---	---	---
S	---	38	49	47,5	55	---	---	---	---
S ₂	---	2	2,5	5,5	3	---	---	---	---
V ₁	---	M6x8 (4)	M6x12,5(4)	M8x14 (4)	M8x14 (4)	---	---	---	---
PB									
G _{1 (H8)}	---	---	60	---	70	---	---	---	---
P ₁	---	---	110	---	116	---	---	---	---
R ₁	---	---	75	---	85	---	---	---	---
S	---	---	49	---	67	---	---	---	---
S ₂	---	---	2,5	---	4	---	---	---	---
V ₁	---	---	M6x12,5(4)	---	M8x14 (4)	---	---	---	---

Dimensioni non impegnative

- Not binding dimensions

- unverbindliche Abmessungen

VARVEL - RS & RT

DIMENSIONI DI INGOMBRO
OVERALL DIMENSIONS
ABMESSUNGEN

RS
ACCESSORI
ACCESSORIES
ZUBEHÖRE

AS

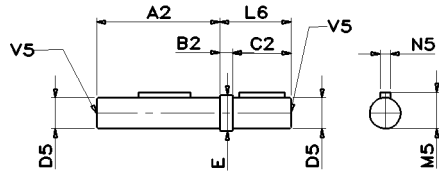

AD

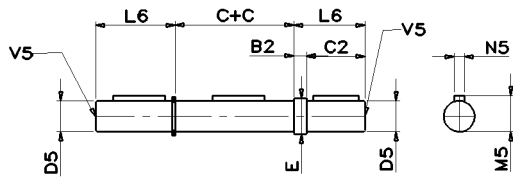

ASC

Protezione di sicurezza
per AS
Safety cap for AS
Wellenschutz für AS

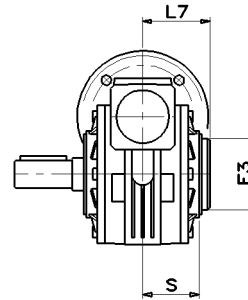

BR

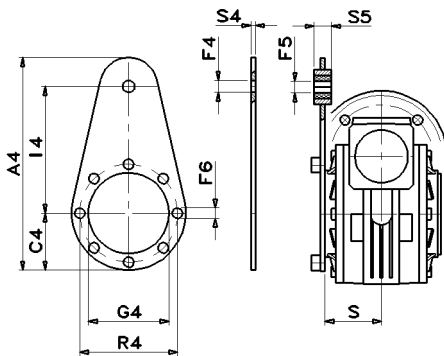

BR

BRV

SL

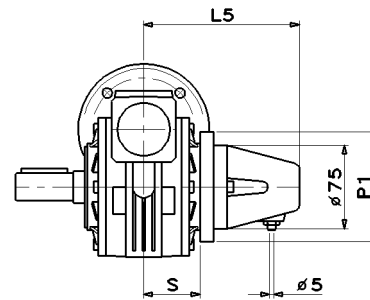

TL

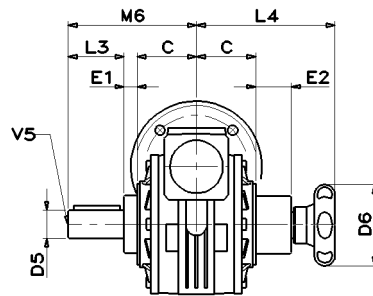

TLE

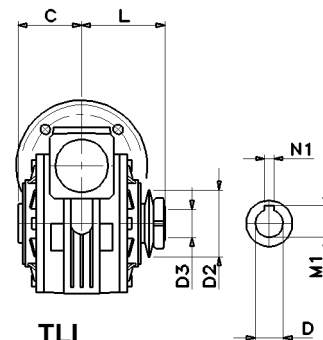

TLI

Litri / Litres	
28	0.04
40	0.10
50	0.13
60	0.30
70	0.45
85	0.75
110	2.25

VB

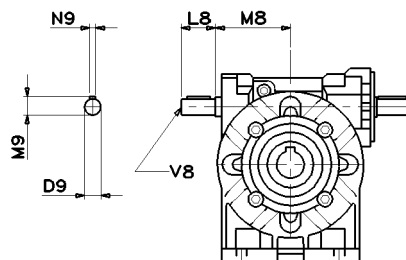

RS

ACCESSORI
ACCESSORIES
ZUBEHÖRE

VARVEL - RS & RT

DIMENSIONI DI INGOMBRO
OVERALL DIMENSIONS
ABMESSUNGEN

RS	28	40	50	60	70	85	110	130	150
AS & AD A ₂	58	80	95	117	117	119	153	177	207
B ₂	1	10	10	10	10	10	10	20	20
C	30	41	49	60	60	61	77,5	90	105
C ₂	30	40	45	50	60	70	100	110	110
D ₅ (g6)	14	19 (18)	24 (25)	25	28	32 (35)	42	48	55
E	14	22	28	30	34	38	50	58	63
L ₆	31	50	55	60	70	80	110	130	130
M ₅	16	21,5	27	28	31	35	45	51,5	59
N ₅	5	6	8	8	8	10	12	14	16
V ₅	M5x10	M8x20	M8x20	M8x20	M8x20	M10x25	M10x25	---	---
ASC E ₃	42	55	62	62	72	90	120	---	---
L ₇	36	48,5	55,5	68,5	67	77	85	---	---
S	27,5	38,5	46,5	57	57	67	74	---	---
BR & BRV A ₄	133,5	165	185	230	240	313	388	465	525
C ₄	33,5	50	60	50	60	75	100	120	125
F ₄	10,5	10,5	10,5	10,5	10,5	20,5	20,5	26	26
F ₅	10	10	10	10	10	20	20	25	25
F ₆	7	7	9	9	9	11	13	13	15
G ₄	42	60	70	70	80	110	130	180	180
I ₄	80	90	100	150	150	200	250	300	350
R ₄	56	83	85	85	100	130	165	215	215
S ₄	4	4	4	6	6	6	6	6	6
S ₅	15	15	15	20	20	25	25	30	30
SL L ₅	97	114	129	137	133	133	151	---	---
P ₁	67	100	110	102	120	150	200	---	---
S	32	38	49	57,5	57	56,5	74,5	---	---
TLE D ₆	52	70	70	70	80	100	100	---	---
E ₁	10	12	12	15	14	19	24	---	---
E ₂	28	37	31	40	46	57	71	---	---
L ₃	30	40	50	50	60	70	80	---	---
L ₄	94	116	118	128	146	168	201	---	---
M ₆	70	93	111	125	134	150	181	---	---
TLI D _(H7)	14	19	24	25	28	32	42	---	---
D ₂	40	56	71	71	80	90	125	---	---
D ₃	14,2 x 20	19,5 x 20,5	24,5 x 28	25,5 x 26	28,5 x 22	32,5 x 27	42,5 x 38,5	---	---
L	45	61,5	77	86,5	89	94	109	---	---
M ₁	15,4*	21,8	27,3	27,3*	31,3	35,3	45,3	---	---
N ₁ (H9)	5	6	8	8	8	10	12	---	---
VB D ₉	9	11	14	19	19	24	28	38	42
L ₈	20	23	30	40	40	50	60	80	100
M ₈	43	55	65	77	84	106,5	145	166	195
M ₉	10,2	12,5	16	22,5	22,5	27	31	41	45
N ₉	3	4	5	6	6	8	8	10	12
V ₈	M4x10	M4x10	M6x15	M8x20	M8x20	M8x20	M8x20	M10x22	M12x25

* = Chiavetta ribassata

- Undersized key

- Passfedernut mit geringerer Tiefe

D₅ (,,) = Diametro a richiesta

- Diameter on demand

- Durchmesser auf Anfrage

VARVEL - RS & RT

RT

DIMENSIONI DI INGOMBRO
 OVERALL DIMENSIONS
 ABMESSUNGEN

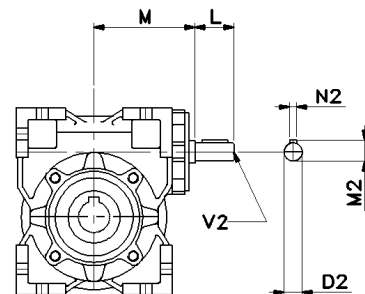
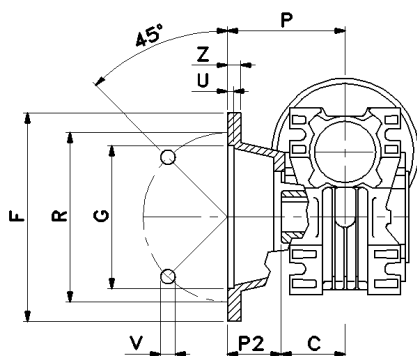
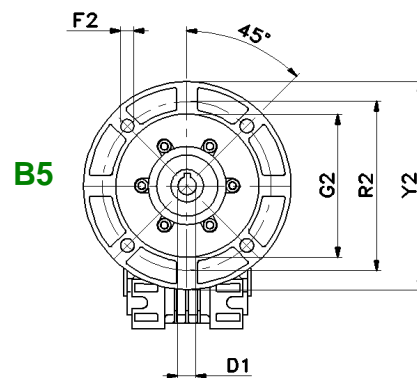
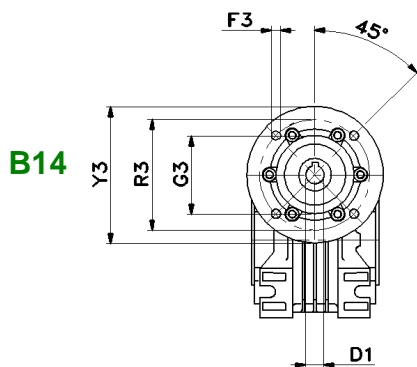
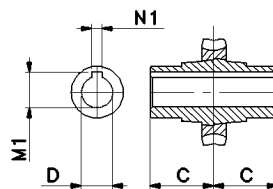
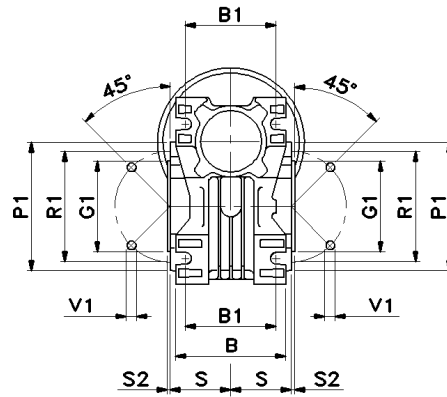
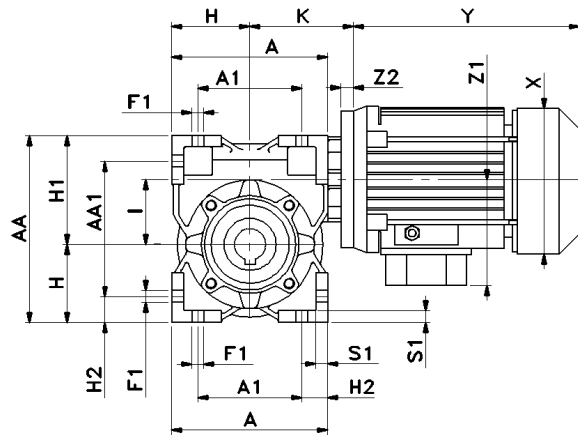

F, [FV], {FL}

RT

RT

VARVEL - RS & RT

DIMENSIONI DI INGOMBRO
OVERALL DIMENSIONS
ABMESSUNGEN

RT	28	40	50	60	70	85	110
A	80	100	120	144	172	206	255
A ₁	54	70	80	100	120	140	170
AA	97	121,5	144	174	205	238	295
AA ₁	71	91,5	104	130	153	172	210
B	53	71	85	100	112	130	144
B ₁	44	60	70	85	90	100	115
C	30	41	49	60	60	61	77,5
D ^(H7)	14	19	24	25	28	32	42
D* ^(H7)	---	18	25	---	30	35	---
D ₂ ^(h6)	9	11	14	19	19	24	28
F	80	110 {110}	125 [160] 125}	180 {180}	200	210	270
F ₁	7	7	9	9	11	13	15
G ^(H8)	50	60 {60}	70 [110] {70}	115 {115}	130	152	170
G ₁ ^(h8)	55	60	70	80	95	110	130
H	40	50	60	72	86	103	127,5
H ₁	57	71,5	84	102	119	135	167,5
H ₂	13	15	20	22	26	33	42,5
I	28	40	50	60	70	85	110
K	57,5	70,5	83-88*	93-94*	117-118*	134-137*	151-153*
L	20	23	30	40	40	50	60
M	50	65	75	87	110	123,5	146
M ₁	16,3	21,8	27,3	28,3	31,3	35,3	45,3
M ₂	10,2	12,5	16	22,5	22,5	27	31
N ₁	5	6	8	8	8	10	12
N ₂	3	4	5	6	6	8	8
P	53	69 {99}	93 [90,5] {123}	86 {116}	111	111	131
P ₁	75	86	100	110	130	160	200
P ₂	23	28 {58}	44 [41,5] {74}	25 {56}	51	50	53,5
R	68	87 {87}	90 [130] {90}	150,5 {150,5}	165	175	230
R ₁	65	75	85	95	115	130	165
S	27,5	38,5	46,5	57	57	67	74
S ₁	6	7	8	10	11	14	13
S ₂	2,5	2,5	3	3	3	3	3,5
U	10	4 {4}	5 [11] {5}	6,5 {6,5}	12	6	5
V	7	9 {9}	11 [9] {9}	11 {11}	13	13	14
V ₁	M6x10 (4)	M6x8,5 (4)	M8x10 (4)	M8x16 (8)	M8x16 (8)	M10x18 (8)	M10x21 (8)
V ₂	M4x10	M4x10	M6x15	M8x20	M8x20	M8x20	M8x20
Z	7	6 {8}	10 [13] {10}	10 {10}	14	16	18
Z ₂	13	13	13 - 18,5	14 - 15	15,5 - 17,5	15,5 - 18,5	18-20

D* - Foro a richiesta

- Bore on demand

- Durchmesser auf Anfrage

V₁ - 90° per RT28

- 90° for RT28

- 90° nur RT28

(*) - IEC71-B14 (FRT50) - IEC71-B14 (FRT60) - IEC 80-B14 (FRT70) - IEC 90-B14 (FRT85) - IEC100/112-B14 (FRT110)

Dimensioni motore: vedi pag, 24

- Motor dimensions: see page 24

- Abmessungen Motor: siehe Seite 24

Dimensioni non impegnative

- Not binding dimensions

- unverbindliche Abmessungen

VARVEL - RS & RT

TA

DIMENSIONI DI INGOMBRO
OVERALL DIMENSIONS
ABMESSUNGEN

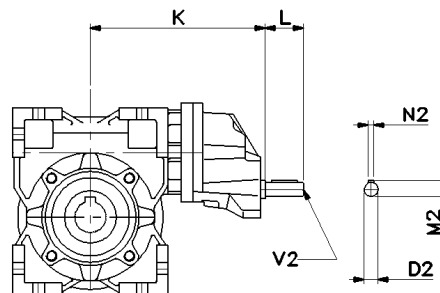
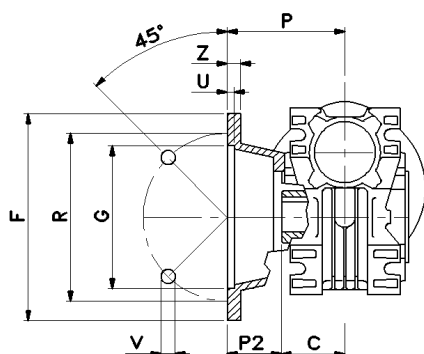
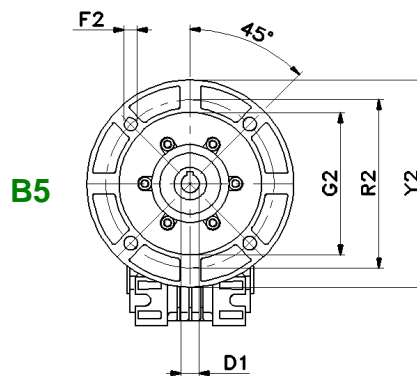
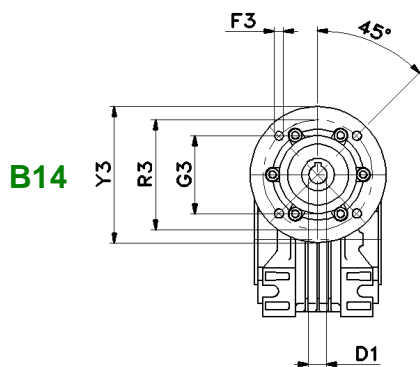
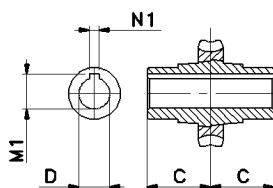
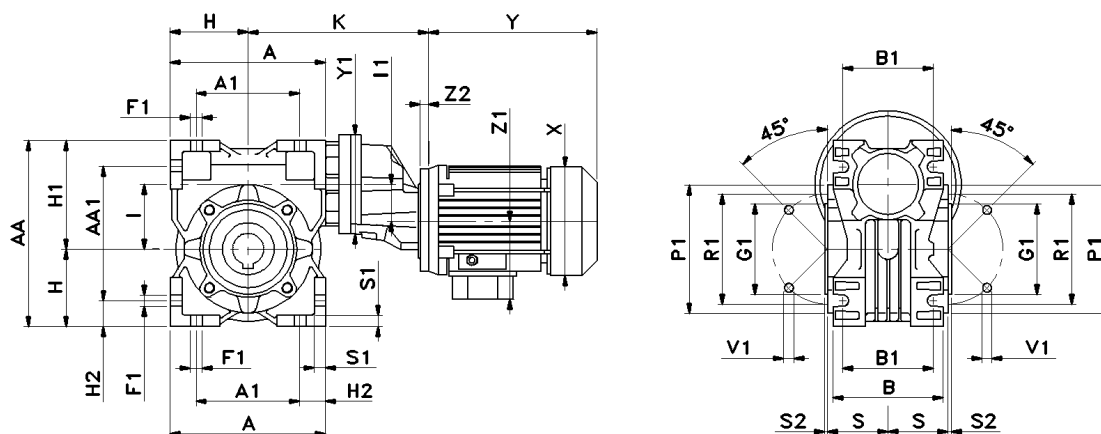

F, [FV], FL}

TA

TA

VARVEL - RS & RT

DIMENSIONI DI INGOMBRO
OVERALL DIMENSIONS
ABMESSUNGEN

TA	63/40	63/50	63/60	71/50	71/60	71/70	71/85	80/60	80/70	80/85	80/110	100/110
AA	121,5	144	174	144	174	205	238	174	205	238	295	295
AA ₁	91,5	104	130	104	130	153	172	130	153	172	210	210
B	71	85	100	85	100	112	130	100	112	130	144	144
B ₁	60	70	85	70	85	90	100	85	90	100	115	115
C	41	49	60	49	60	60	61	60	60	61	77,5	77,5
D _(H7)	19	24	25	24	25	28	32	25	28	32	42	42
D*	18	25	---	25	---	30	35	---	30	35	---	---
D ₂	11	11	11	14	14	14	14	19	19	19	19	24
F	110 {110}	125 [160] {125}	180 {180}	125 [160] {125}	180 {180}	200	210	180 {180}	200	210	270	270
F ₁	7	9	9	9	9	11	13	9	11	13	15	15
G _(H8)	60 {60}	70 [110] {70}	115 {115}	70 [110] {70}	115 {115}	130	152	115 {115}	130	152	170	170
G _{1 (H8)}	60	70	80	70	80	95	110	80	95	110	130	130
H	50	60	72	60	72	86	103	72	86	103	127,5	127,5
H ₁	71,5	84	102	84	102	119	135	102	119	135	167,5	167,5
H ₂	15	20	22	20	22	26	33	22	26	33	42,5	42,5
I	40	50	60	50	60	70	85	60	70	85	110	110
I ₁	32	32	32	40	40	40	40	50	50	50	50	50
K	153,5	171	177	173-178*	183 188*	209-214*	224 229*	207	232,5	250,5	264,5	328
L	23	23	23	30	30	30	30	40	40	40	40	50
M ₁	21,8	27,3	28,3	27,3	28,3	31,3	35,3	28,3	31,3	35,3	45,3	45,3
M ₂	12,5	12,5	12,5	16	16	16	16	22,5	22,5	22,5	22,5	27
N ₁	6	8	8	8	8	8	10	8	8	10	12	12
N ₂	4	4	4	5	5	5	5	6	6	6	6	8
P	69 {99}	93 [90,5] {123}	86 {116}	93 [90,5] {123}	86 {116}	111	111	86 {116}	111	111	131	131
P ₁	86	100	110	100	110	130	160	110	130	160	200	200
P ₂	28 {58}	44 [41,5] {74}	25 {56}	44 [41,5] {74}	25 {56}	51	50	25 {56}	51	50	53,5	53,5
R	87 {87}	90 [130] {90}	150,5 {150,5}	90 [130] {90}	150,5 {150,5}	165	175	150,5 {150,5}	165	175	230	230
R ₁	75	85	95	85	95	115	130	95	115	130	165	165
S	38,5	46,5	57	46,5	57	57	67	57	57	67	74	74
S ₁	7	8	10	8	10	11	14	10	11	14	13	13
S ₂	2,5	3	3	3	3	3	3	3	3	3	3,5	3,5
U	4 {4}	5 [11]{5}	6,5 {6,5}	5 [11] {5}	6,5 {6,5}	12	6	6,5 {6,5}	12	6	5	5
V	9 {9}	11 [9]{9}	11 {11}	11 [9]{9}	11 {11}	13	13	11 {11}	13	13	14	14
V ₁	M6x8 (4)	M8x10 (4)	M8x16 (8)	M8x10 (4)	M8x16 (8)	M8x16 (8)	M10x18 (8)	M8x16 (8)	M8x16 (8)	M10x18 (8)	M10x21 (8)	M10x21 (8)
V ₃	M4 x 10	M4 x 10	M4 x 10	M6 x 15	M6 x 15	M6 x 15	M6 x 15	M8 x 20	M8 x 20	M8 x 20	M8 x 20	M8 x 20
Y ₁	105	105	105	120	120	120	120	140	140	140	140	140
Z	6 {8}	10 [13]{10}	10 {10}	10 [13]{10}	10 {10}	14	16	10 {10}	14	16	18	18
Z ₂	13	13	13	13 - 18,5	13 - 18,5	13 - 18,5	13 - 18,5	14 - 15	14 - 15	14 - 15	14 - 15	14 - 15
AA	121,5	144	174	144	174	205	238	174	205	238	295	295
AA ₁	91,5	104	130	104	130	153	172	130	153	172	210	210

D* - Foro a richiesta

- Bore on demand

- Durchmesser auf Anfrage

V₁ - 90° per RT28

- 90° for RT28

- 90° nur RT28

(*) - IEC71-B14 (FTA 71/....)

Dimensioni motore: vedi pag, 24

- Motor dimensions: see page 24

- Abmessungen Motor: siehe Seite 24

Dimensioni non impegnative

- Not binding dimensions

- unverbindliche Abmessungen

VARVEL - RS & RT

RT/RT

DIMENSIONI DI INGOMBRO
OVERALL DIMENSIONS
ABMESSUNGEN

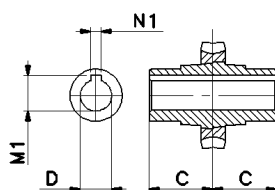
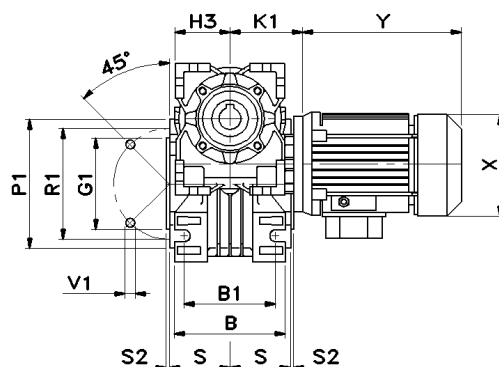
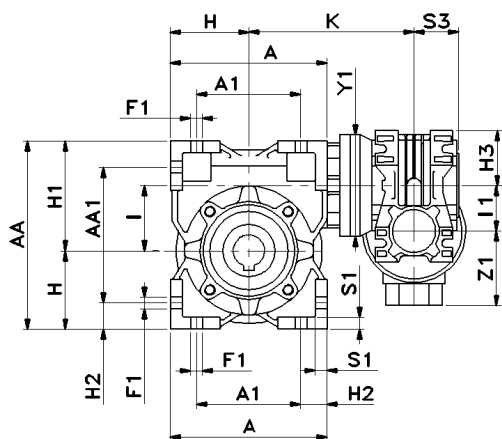

B14

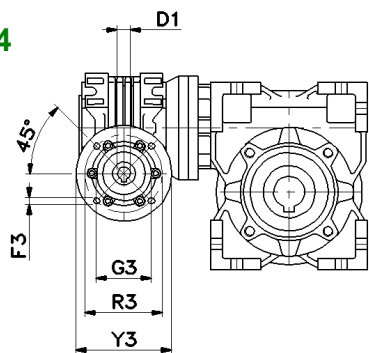

B5

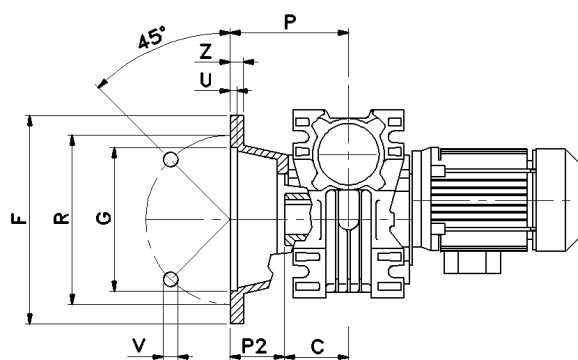
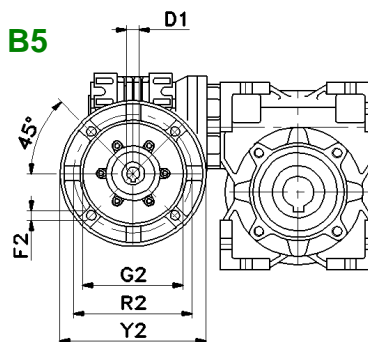

F, {FV}, {FL}

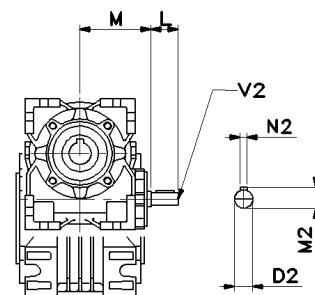

RT/RT

RT/RT

VARVEL - RS & RT

DIMENSIONI DI INGOMBRO
OVERALL DIMENSIONS
ABMESSUNGEN

RT/RT	28/28	28/40	28/50	28/60	40/70	40/85	50/110
A	80	100	120	144	172	206	255
A ₁	54	70	80	100	120	140	170
AA	97	121,5	144	174	205	238	295
AA ₁	71	91,5	104	130	153	172	210
B	53	71	85	100	112	130	144
B ₁	44	60	70	85	90	100	115
C	30	41	49	60	60	61	77,5
D (H7)	14	19	24	25	28	32	42
D* (H7)	---	18	25	---	30	35	---
D ₂ (h6)	9	9	9	9	11	11	14
F	80	110 {110}	125 [160] {125}	180 {180}	200	210	270
F ₁	7	7	9	9	11	13	15
G (H8)	50	60 {60}	70 [110] {70}	115 {115}	130	152	170
G ₁ (h8)	55	60	70	80	95	110	130
H	40	50	60	72	86	103	127,5
H ₁	57	71,5	84	102	119	135	167,5
H ₂	13	15	20	22	26	33	42,5
H ₃	40	40	40	40	50	50	60
I	28	40	50	60	70	85	110
I ₁	28	28	28	28	40	40	50
K	79,5	99,5	129	145,5	143,5	199	203
K ₁	57,5	57,5	57,5	57,5	70,5	70,5	83 - 88*
L	20	20	20	20	23	23	30
M	50	50	50	50	65	65	75
M ₁	16,3	21,8	27,3	28,3	31,3	35,3	45,3
M ₂	10,2	10,2	10,2	10,2	12,5	12,5	16
N ₁	5	6	8	8	8	10	12
N ₂	3	3	3	3	4	4	5
P	53	69 {99}	93 [90,5] {123}	86 {116}	111	111	131
P ₁	75	86	100	110	130	160	200
P ₂	23	28 {58}	44 [41,5] {74}	25 {56}	51	50	53,5
R	68	87 {87}	90 [130] {90}	150,5 {150,5}	165	175	230
R ₁	65	75	85	95	115	130	165
S	27,5	38,5	46,5	57	57	67	74
S ₁	6	7	8	10	11	14	13
S ₂	2,5	2,5	3	3	3	3	3,5
S ₃	30	30	30	30	41	41	49
U	10	4 {4}	5 [11] {5}	6,5 {6,5}	12	6	5
V	7	9 {9}	11 [9] {9}	11 {11}	13	13	14
V ₁	M6x10 (4)	M6x8,5 (4)	M8x10 (4)	M8x16 (8)	M8x16 (8)	M10x18 (8)	M10x21 (8)
V ₂	M4x10	M4x10	M4x10	M4x10	M4x10	M4x10	M6x15
Y ₁	80	90	90	90	120	120	120
Z	7	6 {8}	10 [13] {10}	10 {10}	14	16	18

D* - Foro a richiesta

- Bore on demand

- Durchmesser auf Anfrage

V1 - 90° per RT28

- 90° for RT28

- 90° nur RT28

(*) - IEC71-B14 (FRT50)

Dimensioni motore: vedi pag, 24

- Motor dimensions: see page 24

- Abmessungen Motor: siehe Seite 24

Dimensioni non impegnative

- Not binding dimensions

- unverbindliche Abmessungen

VARVEL - RS & RT

DIMENSIONI DI INGOMBRO
OVERALL DIMENSIONS
ABMESSUNGEN

RT
ACCESSORI
ACCESSORIES
ZUBEHÖRE

AS

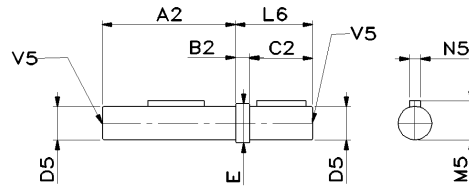

AD

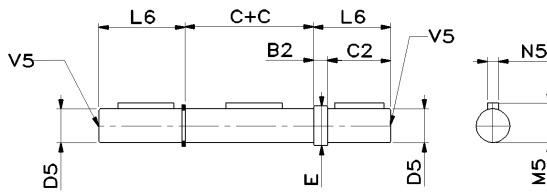

ASC

Protezione di sicurezza
per AS
Safety cap for AS
Wellenschutz für AS

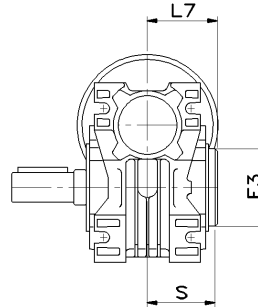

BT

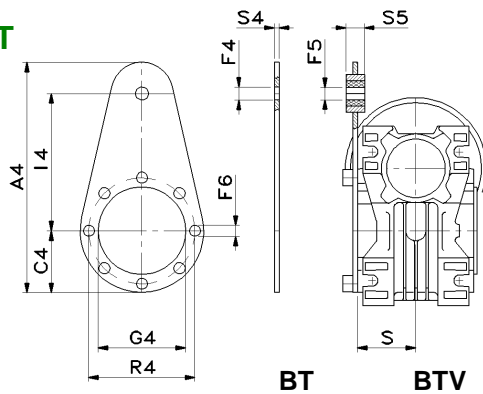

SL

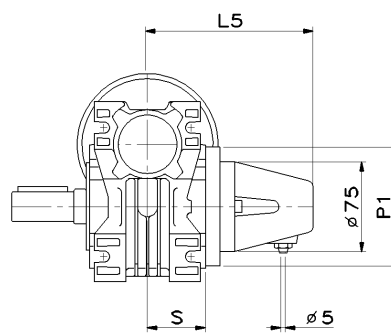

TL

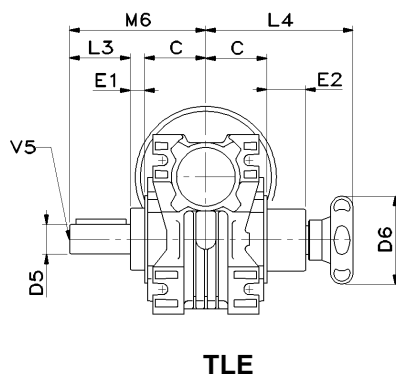

TLI

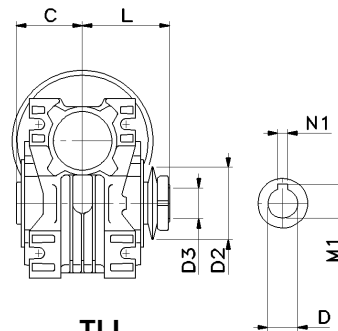

VB

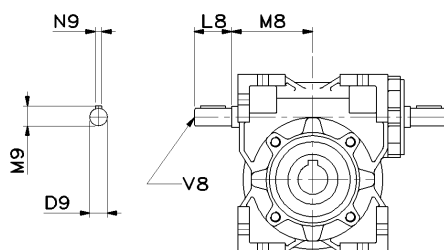

Litri / Litres	
28	0.04
40	0.10
50	0.13
60	0.30
70	0.45
85	0.75
110	2.25

RT

**ACCESSORI
ACCESSORIES
ZUBEHÖRE**

VARVEL - RS & RT

**DIMENSIONI DI INGOMBRO
OVERALL DIMENSIONS
ABMESSUNGEN**

RT	28	40	50	60	70	85	110
AS & AD A ₂	58	80	95	117	117	119	153
B ₂	1	10	10	10	10	10	10
C	30	41	49	60	60	61	77,5
C ₂	30	40	45	50	60	70	110
D ₅ (g6)	14	19 (18)	24 (25)	25	28	32 (35)	42
E	14	22	28	30	34	38	50
L ₆	31	50	55	60	70	80	110
M ₅	16	21,5	27	28	31	35	45
N ₅	5	6	8	8	8	10	12
V ₅	M5x10	M8x20	M8x20	M8x20	M8x20	M10x25	M10x25
ASC E ₃	50	52	62	75	90	100	120
L ₇	36	48,5	55,5	68,5	67	77	85
S	27,5	38,5	46,5	57	57	67	74
BT & BTV A ₄	138	168	185	235	295	313	388
C ₄	38	43	60	55	65	75	100
F ₄	10,5	10,5	10,5	10,5	10,5	20,5	20,5
F ₅	10	10	10	10	10	20	20
F ₆	7	7	9	9	9	12	13
G ₄	55	60	70	80	95	110	130
I ₄	80	100	100	150	200	200	250
R ₄	65	75	85	95	115	130	165
S ₄	4	4	4	6	6	6	6
S ₅	15	15	15	20	20	25	25
SL L ₅	96	113	123	133	133	139	150
P ₁	78	90	100	110	130	160	200
S	27,5	38,5	46,5	57	57	67	74
TLE D ₆	52	70	70	70	80	100	100
E ₁	10	12	12	15	14	19	24
E ₂	28	37	31	40	46	57	71
L ₃	30	40	50	50	60	70	80
L ₄	94	116	118	128	146	168	201
M ₆	70	93	111	125	134	150	181
TLI D _(H7)	14	19	24	25	28	32	42
D ₂	40	56	71	71	80	90	125
D ₃	14,2 x 20	19,5 x 20,5	24,5 x 28	25,5 x 26	28,5 x 22	32,5 x 27	42,5 x 38,5
L	45	61,5	77	86,5	89	94	109
M ₁	15,4*	21,8	27,3	27,3*	31,3	35,3	45,3
N ₁ (H9)	5	6	8	8	8	10	12
VB D ₉	9	11	14	19	19	24	28
L ₈	20	23	30	40	40	50	60
M ₈	43	55	65	77	84	106,5	145
M ₉	10,2	12,5	16	22,5	22,5	27	31
N ₉	3	4	5	6	6	8	8
V ₈	M4x10	M4x10	M6x15	M8x20	M8x20	M8x20	M8x20

D₅ (,,) = Diametro a richiesta

- Diameter on demand

- Durchmesser auf Anfrage

VARVEL - RS & RT

XA

DIMENSIONI DI INGOMBRO
OVERALL DIMENSIONS
ABMESSUNGEN

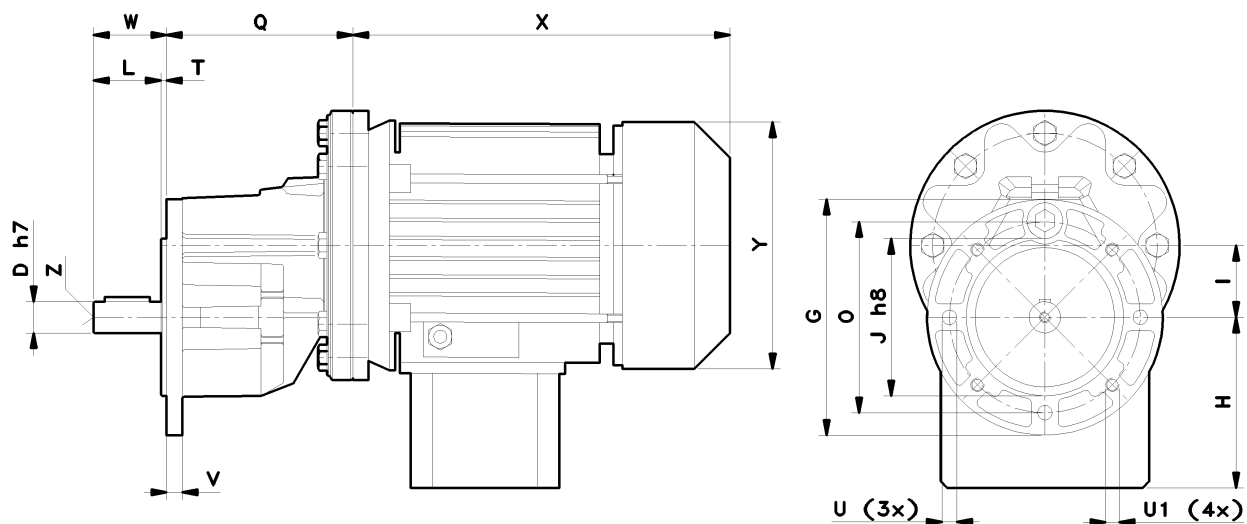

XA	D _{H7}	G	I	J _{h8}	L	O	Q	U	U1	T	V	W	Z
63	14	105	32	70	30	85	83	6,5	M6	2,5	7	32,5	M5x10
71	19	120	40	80	40	100	90	5,5	M6	2,5	7,5	42,5	M8x20
80	24	140	50	95	49,5	115	114	9	M8	2,5	10,5	52	M8x20
100	28	200	63	130	57,5	165	177	10,5	10,5	2,5	12	60	M10 x 22

IEC	56	63	71	80	90 S / L	100	112
H	108	110	121	138	149	160	160
X	168	185	215	238	255 / 280	309	309
Y	110	123	140	159	176	195	195

Peso - Weight - Gewicht XA 63: 1.50 kg
XA 71: 2.00 kg
XA 80: 3.00 kg
XA 100: 7.00 kg

VARVEL - RS & RT

REVERSIBILITÀ E IRREVERSIBILITÀ BACK-DRIVING AND SELF-LOCKING UMKEHRBARKEIT UND SELBSTHEMMUNG

Azionando al contrario un riduttore a vite senza fine con la ruota come organo motore, il rendimento è inferiore a quello di un azionamento con vite motrice e, agendo sui dati di progetto, il rendimento può essere ridotto a zero, ottenendo l'irreversibilità dell'ingranamento,

In quest'azionamento al contrario, l'attrito interno tende a bloccare l'ingranamento e, quanto maggior coppia è applicata alla ruota motrice, tanto più l'attrito d'ingranamento aumenta proporzionalmente ostacolando la rotazione,

L'esempio più ovvio è dato dalla frenatura o dall'abbassamento del carico per inerzia, dove la coppia esterna azionerà al contrario la vite,

Un riduttore a vite senza fine è considerato irreversibile quando l'angolo d'elica è inferiore all'angolo d'attrito (arcotangente del coefficiente d'attrito),

Il contatto sulla dentatura è dinamico anche quando la velocità d'ingranamento è zero, in quanto le vibrazioni su un ingranaggio non rotante possono originare il moto nella zona di contatto,

Si consiglia come fattore di sicurezza la scelta di un angolo d'elica di 3° quale condizione di massima irreversibilità e di 10° quale condizione di minima irreversibilità, secondo la tabella delle relazioni fra angolo d'elica ed irreversibilità,

When back-driving a worm gear set using the worm wheel as input, the efficiency is lower than forward-driving and, by varying the design data, back-drive efficiency can be reduced to zero obtaining a self-locking, or irreversible, gear set,

When back-driving the worm gear, internal friction tends to lock the mesh, and the bigger the applied torque is, the more mesh friction increases proportionally augmenting the lockage at the same time,

The most obvious example is during braking or slowing-down where the inertial load will try to back-drive the worm shaft,

A worm gear is intended as a self-locking unit when the lead angle is less than the friction angle (arc tangent of friction coefficient),

Tooth contact is dynamic even when the mesh velocity is zero, as vibrations in a non-rotating gear set can induce motion in the tooth contact,

To provide a safety factor, a 3° lead angle is recommended for full self-locking condition, and 10° lead angle for poor self-locking condition, according to the table of relations between lead angles and self-locking,

Wird das Schneckengetriebe über die Abtriebswelle angetrieben, ist der Wirkungsgrad des Getriebes schlechter als bei Antrieb über die Eingangswelle. Dabei kann in Abhängigkeit von der Verzahnung der Wirkungsgrad bis Null reduziert sein, was eine auftretende Selbsthemmung bis hin zur vollständigen Blockierung zur Folge hat,

Dieser Fall kann beispielsweise bei Abbremsung oder Senkung einer Last auftreten, wenn die Abtriebswelle durch die Last angetrieben wird,

Ein Schneckengetriebe wird als selbsthemmend bezeichnet, wenn der Spiralwinkel kleiner ist als der Reibungswinkel (Arkustangens vom Reibungskoeffizient),

Der Verzahnungseingriff ist dynamisch, auch wenn die Eingriffsgeschwindigkeit Null ist, da Vibrationen auf ein nicht drehendes Rad eine Bewegung hervorrufen können,

Empfohlen wird, als Sicherheitsfaktor, die Wahl eines Spiralwinkels von 3° als Bedingung einer maximalen Selbsthemmung und von 10° als Bedingung einer geringen Selbsthemmung, wie aus der folgenden Tabelle ersichtlich wird,

Elica Lead angle Spiralwinkel	Irreversibilità	Self-locking	Selbsthemmung
$\beta > 20^\circ$	Reversibilità piena	Full reversibility	Volle Umkehrbarkeit
$10^\circ < \beta < 20^\circ$	Reversibilità elevata	High reversibility	Hohe Umkehrbarkeit
$5^\circ < \beta < 10^\circ$	Reversibilità buona Irreversibilità scarsa	Good reversibility Poor self-locking	Gute Umkehrbarkeit Schwache Selbsthemmung
$3^\circ < \beta < 5^\circ$	Reversibilità scarsa Irreversibilità buona	Poor reversibility Good self-locking	Schwache Umkehrbarkeit Gute Selbsthemmung
$1^\circ < \beta < 3^\circ$	Irreversibilità piena	Full self-locking	Volle Selbsthemmung

VARVEL - RS & RT

DATI DI DENTATURA
GEARING DATA
VERZÄHNUNGSDATEN

	i =	5	7	10	15	20	28	40	49	56	70	80	100
RS/RT 28	m_x β z_1	---	1,50 23°11' 4	1,40 16°41' 3	1,40 11°18' 2	1,10 10°23' 2	1,50 6°06' 1	1,10 5°14' 1	0,90 4°19' 1	0,75 3°03' 1	0,60 2°27' 1	0,55 2°37' 1	0,45 2°20' 1
RS/RT 40	m_x β z_1	2,00 30°57' 6	2,10 21°36' 4	2,00 16°41' 3	2,00 11°18' 2	1,50 8°31' 2	2,10 5°39' 1	1,50 4°17' 1	1,25 3°48' 1	1,10 3°25' 1	0,90 3°01' 1	0,80 2°51' 1	0,65 2°38' 1
RS/RT 50	m_x β z_1	2,50 30°57' 6	2,70 23°52' 4	2,50 16°41' 3	2,50 11°18' 2	1,90 8°59' 2	2,70 6°19' 1	1,90 4°31' 1	1,60 4°14' 1	1,40 3°42' 1	1,10 2°44' 1	1,00 2°51' 1	0,80 2°17' 1
RS/RT 60	m_x β z_1	3,15 36°32' 6	3,30 25°33' 4	3,10 19°0' 3	3,10 12°55' 2	2,40 11°18' 2	3,30 6°49' 1	2,40 5°42' 1	2,00 5°11' 1	1,70 3°55' 1	1,40 3°38' 1	1,20 2°51' 1	1,00 2°51' 1
RS/RT 70	m_x β z_1	3,60 34°01' 6	3,90 26°51' 4	3,60 18°38' 3	3,60 12°40' 2	2,80 11°18' 2	3,90 7°12' 1	2,80 5°42' 1	2,30 4°48' 1	2,00 4°05' 1	1,60 3°16' 1	1,40 2°51' 1	1,15 2°38' 1
RS/RT 85	m_x β z_1	4,40 34°47' 6	4,70 26°05' 4	4,40 19°09' 3	4,40 13°02' 2	3,40 11°18' 2	4,70 6°58' 1	3,40 5°52' 1	2,80 4°52' 1	2,50 4°45' 1	2,00 3°48' 1	1,74 3°14' 1	1,40 2°40' 1
RS/RT 110	m_x β z_1	---	6,10 26°22' 4	5,80 20°43' 3	5,80 14°09' 2	4,40 11°18' 2	6,10 7°04' 1	4,40 5°42' 1	3,60 4°43' 1	3,20 4°29' 1	2,60 3°54' 1	2,30 3°39' 1	1,80 2°34' 1
RS 130	m_x β z_1	---	7,25 26°57' 4	6,90 21°20' 3	6,85 14°06' 2	5,35 13°05' 2	7,25 7°14' 1	5,30 6°18' 1	4,35 5°18' 1	4,00 6°20' 1	3,15 4°33' 1	2,70 3°30' 1	2,25 3°40' 1
RS 150	m_x β z_1	---	8,25 25°33' 4	8,00 21°48' 3	8,15 16°22' 2	6,20 13°24' 2	8,45 7°35' 1	6,25 7°07' 1	5,10 5°48' 1	4,60 6°11' 1	3,60 4°17' 1	3,15 3°45' 1	2,60 3°43' 1

m_x = Modulo assiale
 z_1 = N, principi
 β = Angolo d'elica (dx)
20° = Angolo di pressione

m_x = Axial module
 z_1 = Number of starts
 β = Lead angle (rh)
20° = Pressure angle

m_x = Axialmodul
 z_1 = Steigungen
 β = Spiralwinkel (rx)
20° = Eingriffswinkel

VARVEL - RS & RT

SENSO DI ROTAZIONE
DIRECTION OF ROTATION
DREHRICHTUNGEN

- VITE IN ALTO
WORMSHAFT UPWARDS
OBEN SCHNECKE

RS-RT

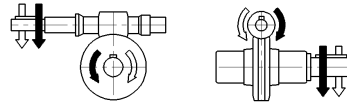

RA-TA

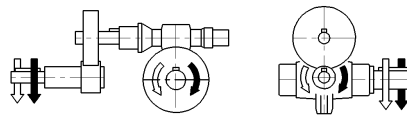

**RS-RS
RT/RT**

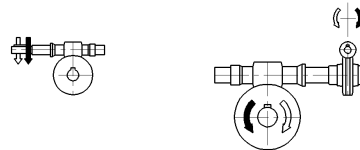

- VITE IN BASSO
WORMSHAFT DOWNWARDS
UNTEN SCHNECKE

RS-RT

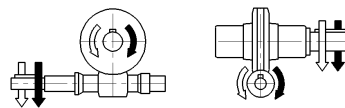

RA-TA

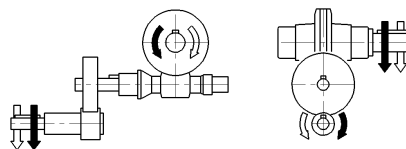

**RS-RS
RT/RT**



VARVEL - RS & RT

Estratto delle ISTRUZIONI D'USO E MANUTENZIONE

Abstract of OPERATION AND MAINTENANCE INSTRUCTIONS

Zusammenfassung der BETRIEBS- UND WARTUNGSANWEISUNGEN

I riduttori e i variatori di velocità non ricadono nel campo d'applicazione della Direttiva Macchine, art.1(2) e non possono essere messi in servizio finché la macchina nella quale devono essere incorporati, sia stata dichiarata conforme all'art. 4(2), all. II(B) delle Direttive Macchine 98/37/CEE/22,6,98 e, solo per l'Italia, al DL 459/24,7,96,

Installazione

Accertarsi che il gruppo da installare abbia le caratteristiche atte a svolgere la funzione richiesta e che la posizione di montaggio sia coerente con quanto ordinato. Tali caratteristiche sono deducibili dalla targhetta d'identificazione apposta sul riduttore. Effettuare la verifica della stabilità del montaggio affinché non si verifichino vibrazioni o sovraccarichi durante il funzionamento,

Funzionamento

Il riduttore può essere collegato per rotazione oraria o antioraria. Arrestare immediatamente il riduttore in caso di funzionamento difettoso o di rumorosità anomala, rimuovere il difetto o ritornare l'apparecchio alla fabbrica per un'adeguata revisione. Se la parte difettosa non è sostituita, anche altri componenti possono essere danneggiati con conseguenti ulteriori danneggiamenti e più scarsa possibilità di risalire alle cause,

Manutenzione

Sebbene i gruppi siano provati con funzionamento senza carico prima della spedizione, è consigliabile non usarli a carico massimo durante le prime 20-30 ore di funzionamento affinché le parti interne possano adattarsi reciprocamente. I riduttori sono spediti già riempiti con olio sintetico a lunga durata e, se occorre sostituire o rabboccare il lubrificante, non mescolare oli a base sintetica con oli a base minerale,

Movimentazione

In caso di sollevamenti con paranco, utilizzare posizioni di aggancio sulla struttura della carcassa, golfari ove esistenti, fori dei piedi o sulle flange, evitando tutte le parti mobili,

Verniciatura

Qualora il gruppo subisca una verniciatura successiva, è necessario proteggere accuratamente gli anelli di tenuta, i piani di accoppiamento e gli alberi sporgenti,

Conservazione prolungata a magazzino

Per permanenze maggiori di tre mesi, è consigliata l'applicazione di antiossidanti su alberi esterni e piani lavorati, e di grasso protettivo sui labbri dei paraolio,

Gestione Ambientale del prodotto

In conformità alla Certificazione Ambientale ISO 14001, sono suggerite le seguenti indicazioni per lo smaltimento del nostro prodotto:

- i componenti del gruppo che vengono rottamati debbono essere consegnati a centri di raccolta autorizzati per i materiali metallici;

gli oli ed i lubrificanti raccolti dal gruppo devono essere smaltiti consegnandoli ai Consorzi Oli esausti;

- gli imballi a corredo dei gruppi (pallet, cartone, carta, plastica, ecc.) vanno avviati per quanto più possibile al recupero/riciclo, consegnandoli a ditte autorizzate per le singole classi di rifiuto,

Variable speed and reduction gearboxes are not part of the field of application of the Machinery Directive, art.1(2), and they must not be put into service until the machinery into which they are to be incorporated, has been declared in conformity with the provision of art.4(2), annex II(B) of Machinery Directives 98/37/CEE/22,6,98 and for Italy only, of DL 459/24,7,96,

Installation

Check if the unit to be installed, is properly selected to perform the required function and that its mounting position complies with the order. The nameplate reports such information. Check mounting stability to run the unit without vibrations or overloads,

Running

The unit may be connected for clockwise or counter-clockwise rotation. The unit must be stopped as soon as defective running or unexpected noise occur, remove the faulty part or return the unit to the factory for checking. If the faulty part is not replaced, other parts can also be affected, causing more severe damage and making the identification of initial cause more difficult,

Maintenance

Although the units are no-load run tested in the factory before despatch, it is recommended not to run them at maximum load for the first 20-30 running hours to allow the proper running in. The gearboxes are delivered already filled with long-life synthetic oil and, in case of replacement or topping, do not mix with mineral lubricants,

Handling

When hoisting, use relevant housing locations or eyebolts if provided, or foot or flange holes. Never hoist on any moving part,

Painting

Carefully protect oil seals, coupling faces and shafts when units are re-painted,

Long-term storage

For storages longer than 3 months, apply anti-oxidants onto shafts and machined surfaces, and protective grease on oil seal lips,

Product's Environmental Management

In conformity with Environmental Certification ISO 14001, we recommend the following to dispose of our products:

- scraped components of the units to deliver to authorized centres for metal object collection;
- oils and lubricants drained from the units to deliver to Exhausted Oil Unions;

- packages (pallets, carton boxes, paper, plastic, etc.) to lead into regeneration/recycling circuits as far as possible, by delivering separate waste classes to authorized companies,

Varvel-Getriebe und Variatoren fallen nicht unter den Geltungsbereich der Maschinenrichtlinien, Artikel 1 (2): Sie dürfen jedoch nicht in Betrieb gesetzt werden, bevor sich nicht Maschinen, in die sie eingebaut werden, mit Artikel 4 (2), Anhang II (B) der Maschinenrichtlinien 98/37/CEE/22,6,98, und (nur für Italien) DL 459/24,07,96, in Übereinstimmung befinden,

Aufstellung

Vor der Aufstellung ist zu prüfen, dass die Antriebseinheit in bezug auf die Betriebsbedingungen richtig ausgewählt wurde und die Einbaulage mit der Bestellung übereinstimmt. Angaben hierüber sind auf dem Typenschild zu finden. Die Stützkonstruktion für die Getriebe ist so stabil auszuführen, dass keine Schwingungen oder Überlastungen auftreten, eventuell sind elastische Kupplungen oder Drehmomentbegrenzer zu verwenden,

Inbetriebnahme

Die Antriebseinheit kann in beiden Drehrichtungen eingesetzt werden. Die Einheit müsst sofort angehalten werden, wenn ein unzulässiger Lauf oder unerwartete Geräusche auftreten. Das fehlerhafte Teil ist zu ersetzen oder die Einheit ist zur Überprüfung einzuschicken. Falls das fehlerhafte Teil nicht ersetzt wird, kann dies zu weiteren Schäden an anderen Bauteilen führen, was eine Feststellung der Ursachen sehr schwierig machen kann,

Wartung

Obwohl die Einheiten vor der Auslieferung im Leerlauf getestet wurden, ist es ratsam sie in den ersten 20-30 Stunden nicht mit Vollast zu betreiben, um ein einwandfreies Einlaufen zu gewährleisten. Die Einheiten werden entsprechend den Angaben auf dem Typenschild mit synthetischem Schmierstoff Lebensdauer geschmiert ausgeliefert. Bei einem eventuellen Ölwechsel oder Nachfüllen darf der Schmierstoff nicht mit Mineralöl vermischt werden,

Handhabung und Transport

Beim Heben und Transport ist auf standsichere Lage und sorgfältige Befestigung geeigneter Hebevorrichtungen zu achten. Bewegliche Teile dürfen nicht zum Anheben benutzt werden,

Anstrich

Beim Erneuern oder dem zusätzlichen Aufbringen eines Anstriches sind die Dichtungen, Kupplungssitze und Wellen sorgfältig zu schützen,

Langzeitlagerung

Die Einlagerung der Einheiten muss trocken und staubfrei erfolgen. Bei einer Einlagerungszeit über 3 Monate sind bearbeitete Flächen und Wellen mit Rostschutzmitteln zu besprühen. Dichtlippen sind mit Fett zu schützen,

Entsorgung

In Übereinstimmung mit ISO 14001 weisen wir darauf hin, im Falle des Verschrottens die einzelnen Metallteile getrennt zu behandeln und Schmiermittel bei den befugten Stellen zu entsorgen. Verpackungen sollten soweit wie möglich wieder verwendet werden,